

VERITAS®

SCHMETZ INSIDE



VERITAS Florence

EN Manual



VERITAS®
Florence

A brilliant model: the lady with the lamp.

The horror, that Florence Nightingale witnessed in the dim light of her oil lamp during the Crimean War of the 1850s, changed everything. She used her unique combination of talent for statistics, compassion with the sick and outrage about the horrific hygiene in the medical tents to achieve a revolutionary goal: the professionalization of nursing. That's why today we celebrate International Nursery Day on her birthday: Mai 12th.



MyPatterns



The app to make embroidery more easy

The app that start's the fun: get an easy grip on all features of VERITAS Florence, adjust all settings with a flick of your finger, use many embroidery templates from the internet.
Download the app now!

Dear customer

We congratulate you on your purchase of your sewing computer. You have bought a quality product which has been made with great care and, if serviced right, will serve you well for many years.

Before using it for the first time, we ask you to read the manual at hand carefully, paying special attention to the safety instructions.

Persons who are not familiar with this manual must not use the appliance.

In this manual, you will find everything there is to know about possible applications of your sewing computer. Should any questions remain unanswered, we kindly ask you to turn to your dealer.

We wish you much pleasure and great sewing successes!

Important safety instructions

When using an electrical appliance, basic safety should always be followed, including the following:

Read all instructions before using this sewing machine.

DANGER - To reduce the risk of electric shock:

1. An appliance should never be left unattended when plugged in.
2. Always unplug this appliance from the electric outlet immediately after using and before cleaning.

WARNING - To reduce the risk of burns, fire, electric shock, or injury to persons:

1. Read the instruction carefully before you use the machine.
2. Keep the instructions at a suitable place close to the machine and hand it over if you give the machine to a third party.
3. Use the machine only in dry locations.
4. Never leave the machine unattended with children or elderly people due to they may not be able to estimate the risk.
5. This appliance can be used by children aged from 8 years and above and persons with reduced physical, sensory or mental capabilities or lack of experience and knowledge if they have been given supervision or instruction concerning use of the appliance in a safe way and understand the hazards involved.
6. Children shall not play with the appliance.
7. Cleaning and user maintenance shall not be made by children without supervision.
8. Always switch off the machine if you carry out preparation for work (change the needle, feed the yarn through the machine, change the footer, etc.).
9. Always unplug the machine if you leave it unattended, to avoid injury by expediently switch on the machine.
10. Always unplug the machine if you carry out maintenance (oiling, cleaning).
11. Don't use the machine if it's wet or in humid environment.
12. Never pull at the cord, always unplug the machine by gripping the plug.
13. If the LED lamp is damaged or broken, it must be replaced by the manufacturer or its service agent or a similarly qualified person, in order to avoid a hazard.
14. Never place anything on the pedal.

15. Never use the machine if the air vents are blocked, keep the air vents of the machine and the foot pedal free from dust, fusel and leftovers.
16. The machine must only be used with designated foot controller, in order to avoid a hazard. If the foot controller is damaged or broken, it must be replaced by the manufacturer or its service agent or a similarly qualified person.
17. The sound pressure level at normal operation is smaller than 75dB(A).
18. Do not dispose of electrical appliances as unsorted municipal waste, use separate collection facilities.
19. Contact your local government for information regarding the collection systems available.
20. If electrical appliances are disposed of in landfills or dumps, hazardous substances can leak into the groundwater and get into the food chain, damaging your health and well-being.
21. When replacing old appliances with new ones, the retailer is legally obligated to take back your old appliance for disposal at least for free of charge.
22. The appliance is not to be used by persons (including children) with reduced physical, sensory or mental capabilities, or lack of experience and knowledge, unless they have been given supervision or instruction. (For outside Europe)
23. Children being supervised not to play with the appliance. (For outside Europe)

SAVE THESE INSTRUCTIONS

This sewing machine is intended for household use only.

Be sure to use the sewing machine in the temperature range from 5°C to 40°C. If the temperature is excessively low, the machine can fail to operate normally.

Correct Use

Danger! Electric shock due to humidity

The sewing machine must only be stored and used in dry rooms.

Humidity and dampness may cause an electric shock.

Danger! Eye injuries due to a broken needle

Only soft, flexible textiles may be sewn.

The machine is not designed for sewing materials such as thick, hard or inflexible leather, tarpaulins, canvas, etc.; the needle may break.

The needle can break if the material is not transported by the motor and is instead pushed or held back by the user.

Danger! Needle-prick injuries if operated accidentally

The machine may only be used by careful adults.

Children from 8 years and persons with restricted abilities may only use the machine after thorough instruction and under constant supervision. They must have understood dangers with regard of the use of the machine.

Children from 8 years and persons with restricted abilities may only do the maintenance and cleaning of the machine after thorough instruction and under constant supervision.

Never leave an operational machine in areas to which children have access. It must be avoided that children play with the machine.

The main switch must be turned off or power plug must be disconnected for all preparation or configuration tasks.

Danger! Risk of injury due to defects or modifications.

The machine must not be modified.

Repairs must be carried out by the technical service.
Damage, modifications, or the use of non-original accessories can lead to injuries.

Danger! Risk of injury due to defects or modifications.

The machine must not be modified.

Repairs must be carried out by the technical service.
Damage, modifications, or the use of non-original accessories can lead to injuries.

Defective machines must no longer be used.

Defective power cords must be replaced by original spare part.

Danger! Unsuitable installation sites (workplaces) can result in accidents.

The machine must only be operated on a stable surface.

Shaky, unstable or untidy workplaces can cause the machine to fall down or cause needle-prick injuries.

Danger! Persons without knowledge of these operating instructions may injure themselves or damage the sewing machine.

Only use this sewing machine if you have a basic knowledge of how to use sewing machines.

Danger! Needle-prick injuries may occur if you do not pay attention.

Take time, ensure the workplace is tidy and guide the material calmly through the machine without using force.

Caution! This machine is designed for use in a private home.
The machine is not approved for professional or commercial use.

Contents

Machine Introduction

| | |
|---|----------|
| Principal parts of the machine | 1 |
| Accessories | 2 |
| Standard | 2 |
| Optional | 2 |
| Connecting machine to power source | 3 |
| Polarized plug information | 3 |
| Foot control (In sewing mode) | 3 |
| Display instruction | 4 |
| Screen | 4 |
| Status Indicator | 6 |

Machine Setup

| | |
|--|-----------|
| Sewing table | 8 |
| Free arm | 8 |
| Two-step presser foot lifter | 9 |
| Using the thread net | 9 |
| Winding the bobbin | 10 |
| Inserting the bobbin | 12 |
| Threading the upper thread | 13 |
| Bringing up the bobbin thread | 16 |
| Replacing the needle | 17 |
| Matching needle/fabric/thread | 18 |
| Changing the presser foot | 19 |
| Remove the presser foot | 19 |
| Attach the presser foot | 19 |
| Remove and insert the presser foot holder | 19 |
| Insert the edge/quilting guide | 19 |
| Replacing the needle plate | 20 |
| To raise or drop the feed dogs | 21 |
| Adjusting the presser foot pressure | 21 |
| Thread tension | 22 |

Instruction

| | |
|---|-----------|
| Operation buttons | 24 |
| Selecting stitch | 27 |
| Altering the stitch length & width | 28 |
| Altering the stitch length | 28 |
| Altering the stitch width | 28 |

Stitch Chart

| | |
|---------------------------|-----------|
| Stitch chart | 30 |
| A Group patterns | 30 |
| B Group patterns | 31 |

Sewing Basics

| | |
|------------------------------------|-----------|
| Straight stitch | 34 |
| Changing the needle position | 34 |
| Zigzag stitch | 35 |

| | |
|------------------------------|-----------|
| Starting to sew | 36 |
| Useful skills | 38 |
| Reverse sewing..... | 38 |
| Sewing curves..... | 38 |
| Sewing corners | 39 |
| Sewing stretch fabrics..... | 39 |
| Sewing thin fabrics..... | 39 |
| Sewing heavy fabric..... | 40 |

Utility Stitches

| | |
|---|-----------|
| Stretch stitch | 42 |
| Straight stretch stitch | 42 |
| Zigzag stretch stitch | 42 |
| Sewing stretch fabrics and elastic tape | 43 |
| Overcasting stitch | 44 |
| Using the all purpose foot | 44 |
| Using the overcasting foot | 44 |
| Blind Hem | 45 |
| Buttonhole stitch | 46 |
| Making a buttonhole on stretch fabrics..... | 48 |
| Eyelet stitch | 49 |
| Button sewing | 50 |
| Zipper insertion | 51 |
| Inserting a centered zipper | 51 |
| Inserting a side zipper..... | 52 |
| Satin stitch sewing | 54 |
| Gathering | 54 |
| Smocking | 55 |
| Free motion darning, embroidery and monogramming | 56 |
| Preparation for embroidering and monogramming..... | 56 |
| Darning..... | 57 |
| Embroidery..... | 57 |
| Monogramming | 57 |
| Quilting | 58 |
| Using the edge/quilting guide..... | 58 |
| Joining the pieces of the fabric | 58 |
| Patchwork stitching | 59 |
| Applique | 60 |
| Fagoting | 60 |
| Scallop stitch | 61 |
| Scallop edging..... | 61 |
| Scallop hem | 61 |

Embroidery Preparation

| | |
|---|-----------|
| Embroidery quick guide | 63 |
| Important embroidery information | 65 |
| Embroidery threads..... | 65 |
| Bobbin threads | 65 |
| Stabilizer | 66 |
| Adhesive Spray | 67 |

| | |
|--|-----------|
| Iron-on interfacing..... | 68 |
| Embroidery unit overview | 69 |
| Embroidery hoop overview | 70 |
| Preparing the embroidery hoop | 70 |
| Attaching a stabilizer to the fabric..... | 70 |
| Hooping the fabric..... | 71 |
| Use the quick release device | 72 |
| Using embroidery sheet..... | 73 |

Embroidery Process

| | |
|--|-----------|
| Step 1. Preparation for embroidery | 76 |
| Step 2. Starting the connection | 78 |
| Embroidery software installation..... | 78 |
| Step 2-A. Connection mode: Router | 79 |
| The first time to set up..... | 79 |
| Connection | 80 |
| Step 2-B. Connection mode: Point-to-point | 81 |
| Step 3. Import/edit embroidery pattern | 82 |
| Importing files on iOS | 82 |
| Importing files on Andriod | 82 |
| Location of imported files on App | 82 |
| Step 4. Install the embroidery hoop | 83 |
| Step 5. Begin to embroider | 84 |
| Load a Design after interruption | 85 |
| Adjust the thread tension | 86 |
| Step 6. Back to sewing mode | 87 |
| Remove embroidery hoop..... | 87 |
| Remove embroidery unit..... | 87 |

Maintenance and Trouble shooting

| | |
|-------------------------------------|-----------|
| Maintenance | 89 |
| Clean the hook | 89 |
| Clean the machine surface | 89 |
| Warning Function | 90 |
| Warning beeping sound | 90 |
| Instruction message display | 90 |
| Trouble shooting guide | 91 |

Embroidery pattern chart

| | |
|---------------------------------------|------------|
| Embroidery pattern chart | 97 |
| Embroidery letter chart | 100 |

Machine Introduction

Principal parts of the machine

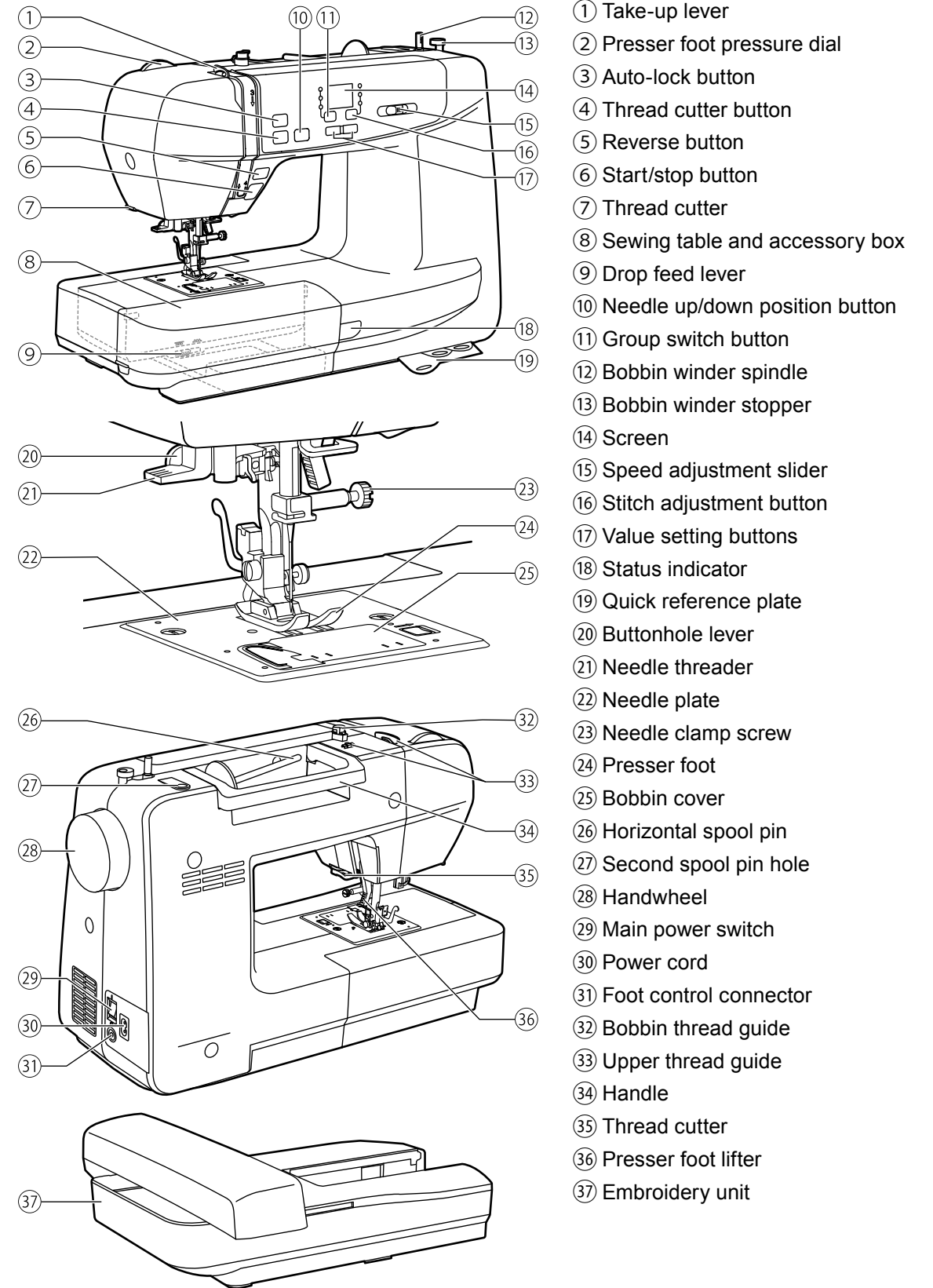

Accessories

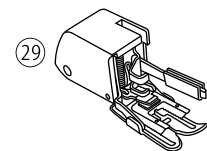
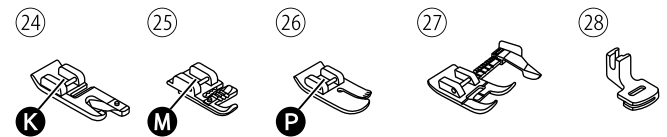
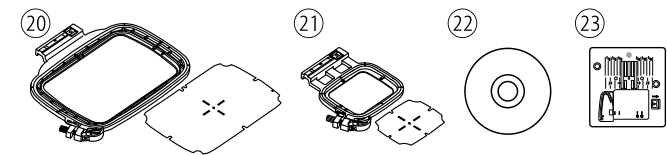
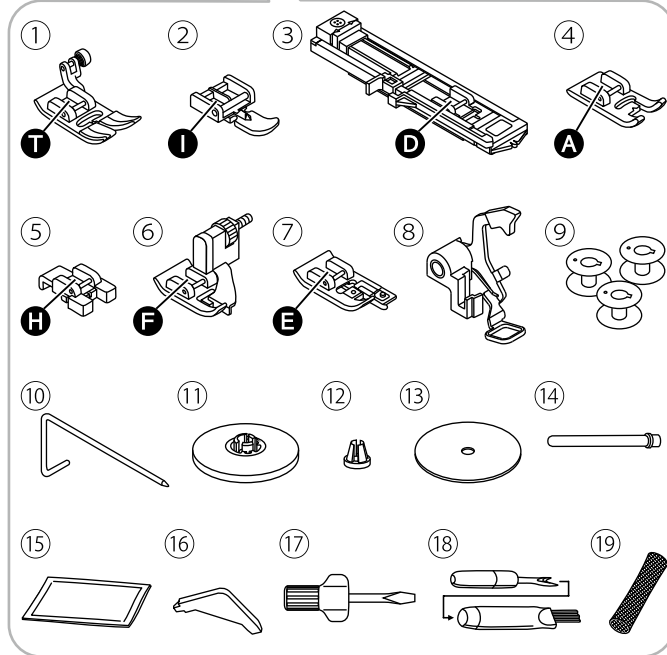
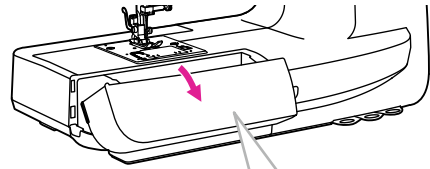

Accessories are stored inside the accessory box.

❖ Standard

- ① All purpose foot
- ② Zipper foot
- ③ Buttonhole foot
- ④ Satin stitch foot
- ⑤ Button sewing foot
- ⑥ Blind hem foot
- ⑦ Overcasting foot
- ⑧ Darning/embroidery foot
- ⑨ Bobbin (3x)
- ⑩ Edge/quilting guide
- ⑪ Spool holder (Large)
- ⑫ Spool holder (Small)
- ⑬ Spool pin felt
- ⑭ Second spool pin
- ⑮ Pack of needles
- ⑯ L-screwdriver
- ⑰ Screwdriver
- ⑱ Seam ripper/brush
- ⑲ Thread net
- ⑳ Embroidery set (120*180mm)
- ㉑ Embroidery set (50*70mm)
- ㉒ CD
- ㉓ Straight stitch plate

❖ Optional

- ⑳ Hemmer foot
- ㉑ Cording foot
- ㉒ Quilting foot
- ㉓ Adjustable guide foot
- ㉔ Gathering foot
- ㉕ Walking foot

Note

To purchase optional accessories, please consult your local dealer for further information.

Connecting machine to power source

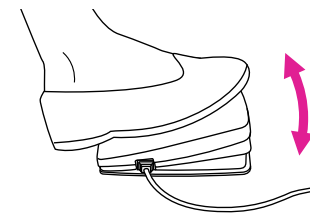
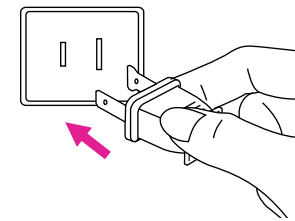
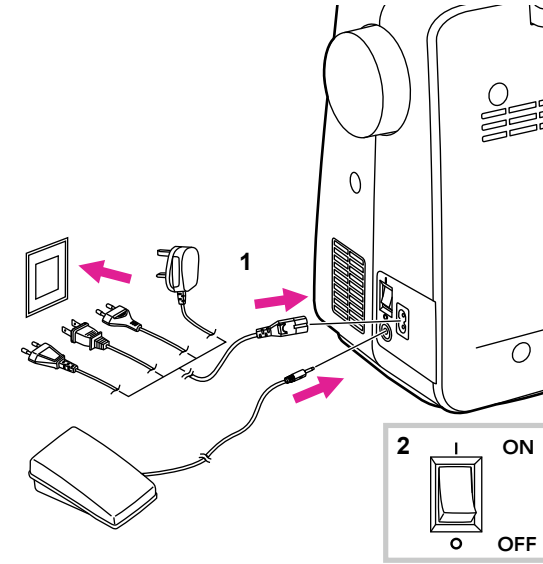

⚠ Attention

Always make sure that the machine is unplugged from power source and the main switch is off ("O"), when the machine is not in use and before inserting or removing parts.

Before connecting the power supply, make sure that the voltage shown on the rating plate is conforming with your main power.

Put the machine on a stable table.

1. Connect the machine to a power source as illustrated.
 2. Turn the power switch to on ("I").
- The sewing lamp will light up when the switch is turned on.

❖ Polarized plug information

This appliance has a polarized plug (one blade is wider than the other), to reduce the risk of electrical shock; this plug will fit in a polarized outlet only one way. If the plug does not fit fully in the outlet, reverse the plug. If it still does not fit, contact a qualified electrician to install the proper outlet. Do not modify the plug in any way.

❖ Foot control (In sewing mode)

When the machine is off, insert the foot control plug into its connector on the machine.

Turn on the machine, and then slowly press down the foot control to start sewing. Release the foot control to stop the machine.

User can quickly kick one step on the foot control to change the needle position and set the stop position at the same time.

⚠ Attention

Foot control will be disabled in embroidery mode.

Note

Consult a qualified electrician if in doubt as to connect the machine to the power source.

Display instruction

❖ Screen

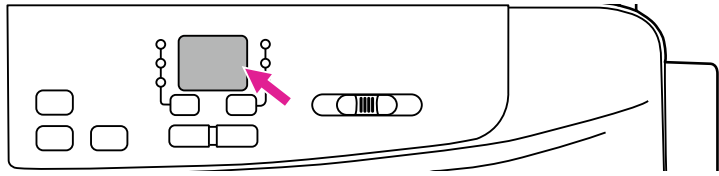

| Operation mode | | |
|----------------|--|-------|
| Screen | In general | Page |
| SP | <p>Winding the bobbin</p> <p>Bobbin winder spindle is on the right for bobbin winding. Push the spindle to the left for sewing.</p> <p>Please refer to "Winding the bobbin" chapter for more information.</p> | 10-12 |
| Screen | Embroidery mode | Page |
| AP | <p>Router mode (AP) starting</p> <p>Under this mode, the machine connects with the mobile device thru the router. Once the setting was done, the machine will connect with the router automatically next time.</p> <p>Please refer to "Starting the connection" "Connection mode: Router" chapter for more information.</p> | 78-80 |
| PP | <p>Point-to-point mode starting</p> <p>Under this mode, the machine connects with the mobile device directly, and the internet access is not available for the mobile device during the connection.</p> <p>Please use this mode when the wifi service is not available or its quality is not well.</p> <p>Please refer to "Starting the connection" "Connection mode: Point-to-point" chapter for more information.</p> | 78,81 |
| OO | <p>Machine connected with tablet devices</p> <p>Please refer to "Starting the connection" "Connection mode: Router" "Connection mode: Point-to-point" chapter for more information.</p> | 78-81 |

| Error messages | | |
|----------------|--|-------|
| Screen | In general | Page |
| UE | <p>Upper thread error</p> <p>The upper thread is broken or running out soon.</p> <p>Please change and re-threading the upper thread. Please refer to "Threading the upper thread" chapter for more information.</p> | 13-15 |

| LE | <p>Lower thread error</p> <p>The lower thread is broken or almost running out, please change and refill the lower thread.</p> <p>Please refer to "Winding the bobbin" and "Inserting the bobbin" chapters for more information.</p> | 10-12 |
|-----------|---|-------|
| EL | <p>Motor overload protection</p> <p>The motor is overloaded due to the jammed threads or the fabrics are too thick to be penetrated.</p> | 90 |
| E1 | <p>Presser foot lifter – wrong position</p> <p>Please check if the presser foot lifter is at the right position. To lower the lifter when sewing and raise it while the embroidery hoop is resetting.</p> | 9 |
| E4 | <p>Buttonhole lever – wrong position</p> <p>Please check if the buttonhole lever is at the right position. To raise the lever in normal use and lower the lever while sewing buttonhole.</p> | 47 |
| EE | <p>Needle position – wrong position</p> <p>After installing the straight stitch plate, if the needle position is in a lower position, turn the handwheel backwards you to bring the needle to the highest position.</p> | - |
| Screen | Embroidery mode | Page |
| E2 | <p>Embroidery hoop is not installed or should be removed</p> | 83,87 |
| E3 | <p>Straight stitch plate is not installed</p> <p>Please refer to "Replacing the needle plate" chapter for more information</p> | 20 |
| E5 | <p>The router cannot connect with the wifi. Please check the wifi service</p> <p>The connection failed because the router might not be in operation or the password is not correct.</p> <p>A.If it was the first time for setting, please check if the password is correct.</p> <p>B.If the router mode had already been set up successfully, please check if the router works normally and is well connected.</p> | 79 |

If the problem is still not solved, please contact your local dealer.

❖ **Status Indicator**

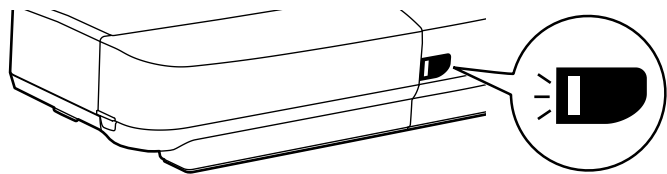

| Display | In general | Sewing mode | Embroidery mode |
|---------------|--|---|--|
| Green | <p>When the upper thread breaks, the motor will stop. Green light will flash 3 times then back resume to constantly bright status.</p> <p>When remaining amount of bobbin thread is low, the motor will stop. Green light will flash 3 times then back resume to constantly bright status.</p> | <p>Constantly bright: Machine is ready to sew; press the start/stop button to start sewing immediately.</p> | <p>Constantly bright: Machine is ready to embroider ; press the start/stop button to start embroidering immediately.</p> |
| Yellow | - | Machine is not able to sew. | Machine is not able to sew. |
| Red | <p>Motor is overloaded or the shaft locked down.</p> <p>Once the problem solved, the lighting will resume to previous condition.</p> | - | - |

Machine Setup

Sewing table

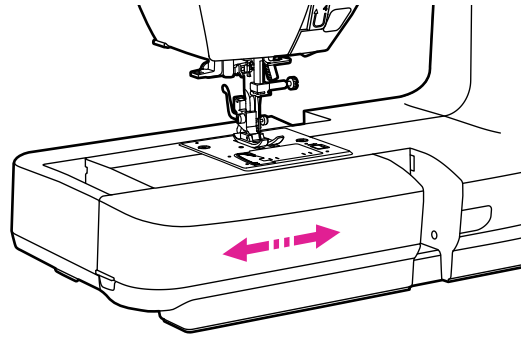

Hold the sewing table horizontally, then pull toward the left to remove it from the machine.

Attach the sewing table, and then push it to the right.

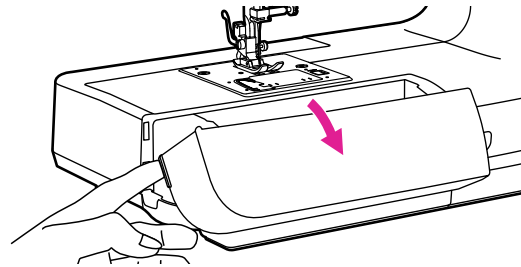

The inside space of the sewing table is used as an accessory box.

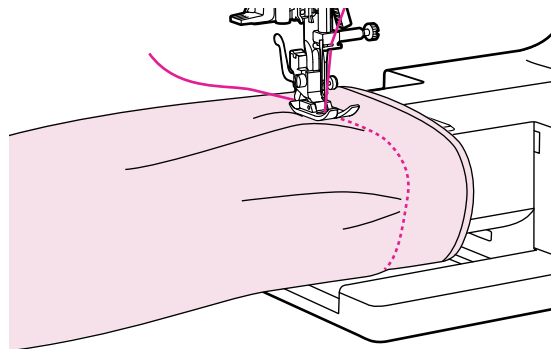

❖ Free arm

Free-arm sewing is convenient for sewing tubular areas such as pant hems and cuffs.

Two-step presser foot lifter

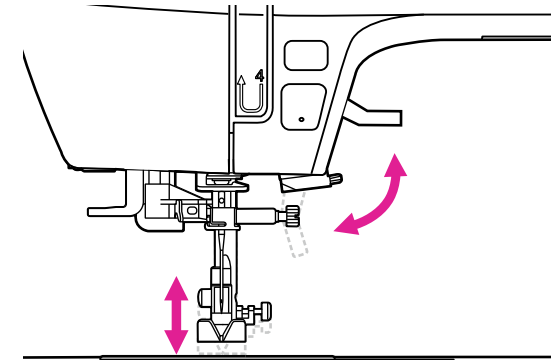

The presser foot lifter is to raise or lower your presser foot.

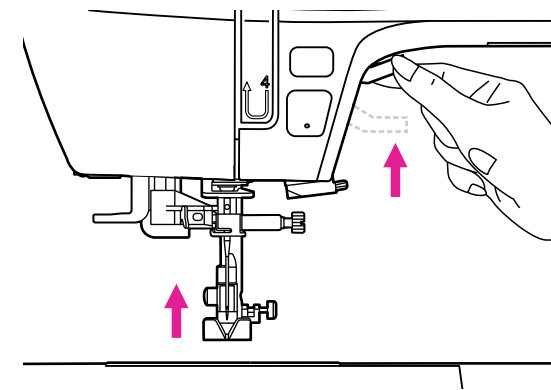

When sewing multi-layers or thick fabrics, the presser foot can be further raised up manually to allow enough space for your sewing work.

Note

The needle must always be at the highest position.

Using the thread net

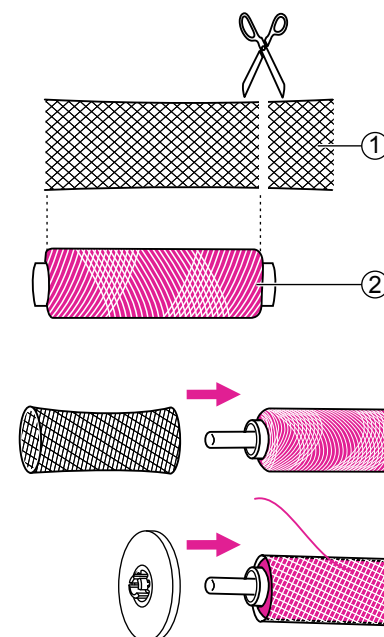

Note

In order to prevent tangling of the thread, please use a thread net. The net is especially useful when using large or loose wound spools.

When using special threads which spin quickly off the thread spool, attach a net to the spool before using.

If the net is too long, cut the thread net to match the size of the spool.

- ① Thread net
- ② Thread

Winding the bobbin

Please following the number order and see the corresponding illustrations below.

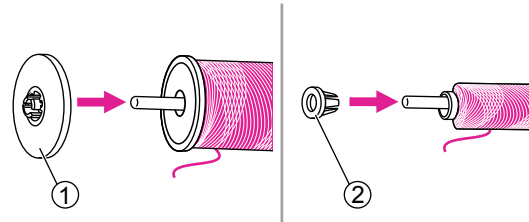
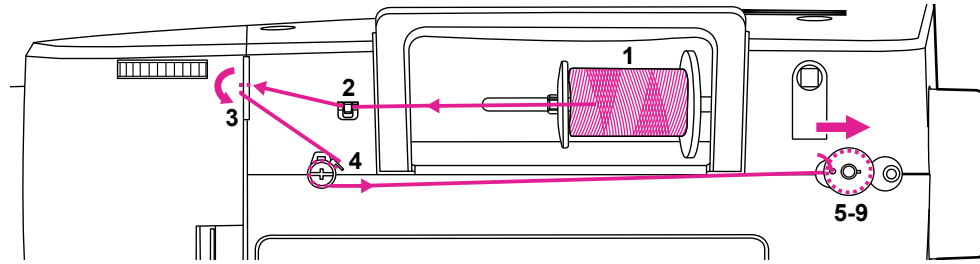

1. Place the thread and spool holder onto the spool pin. For better sewing quality, choose a proper size of the spool holder for the thread and attach it next to the spool.

- ① Large spool holder
- ② Small spool holder

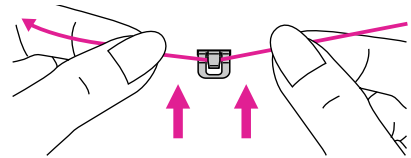

2. Draw the thread from the spool and place the thread in between the upper thread guide.

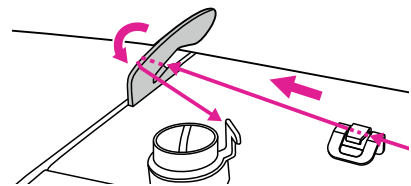

3. Guide the thread ahead and pull the thread through the pre-tension spring as illustrated.

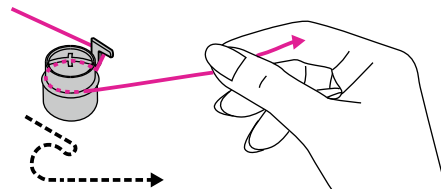

4. Wind the thread counter-clockwise around the tension discs.

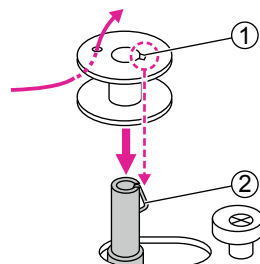

5. Place the thread end through one of the inner holes as illustrated and place the empty bobbin on the bobbin winder spindle. Then align the notch with bobbin winder spindle spring.

- ① Notch
- ② Bobbin winder spindle spring

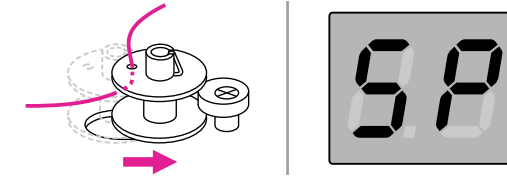

6. Push the bobbin to the right. When the bobbin winder spindle is pushed to the right, the screen will show "SP".

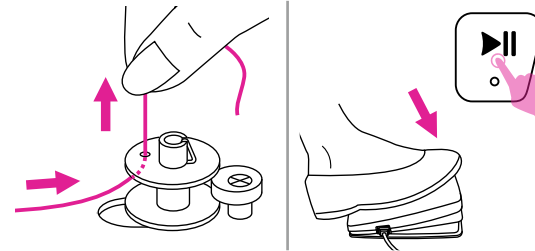

7. Hold the thread tail securely in one hand. Step on the foot control (only in the sewing mode) or long press the start/stop button to start winding the bobbin.

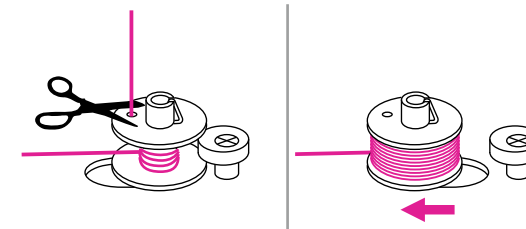

8. After the bobbin has wound a few rounds, stop the machine and cut the thread near the hole of the bobbin. Continue filling the bobbin until it is full. Once the bobbin is full, it rotates slowly. Release the foot control or press the start/stop button to stop the machine, then push the bobbin winder spindle to the left.

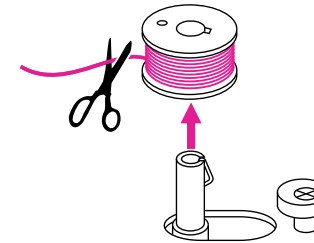

9. Cut the thread and then remove the bobbin.

Note

When the bobbin winder spindle is pushed to the right position, it's in "bobbin winding" mode and the machine is not allowed to sew and the handwheel will not be able to turn. To start sewing, push the bobbin winder spindle back to the left.

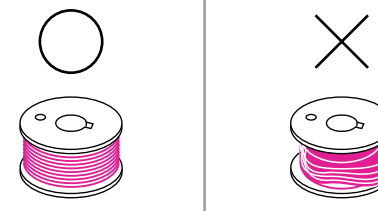

Note

Use a bobbin that has been correctly wound with thread, otherwise the needle may break or the thread tension will be incorrect.

Inserting the bobbin

⚠ Attention

Turn the power switch to off ("O").

When inserting or removing the bobbin, the needle and the presser foot must be fully raised.

Open the bobbin cover by pushing the release button to the right.

① Release button

Insert the bobbin in the bobbin case with the thread running in a counter-clockwise direction (arrow).

Pull the thread through the slit (A).

With a finger hold gently on top of the bobbin, please follow the arrow markings and draw the thread into the bobbin thread guide.

To cut off excessive thread, pull it to the cutter at point (B).

Close the bobbin cover.

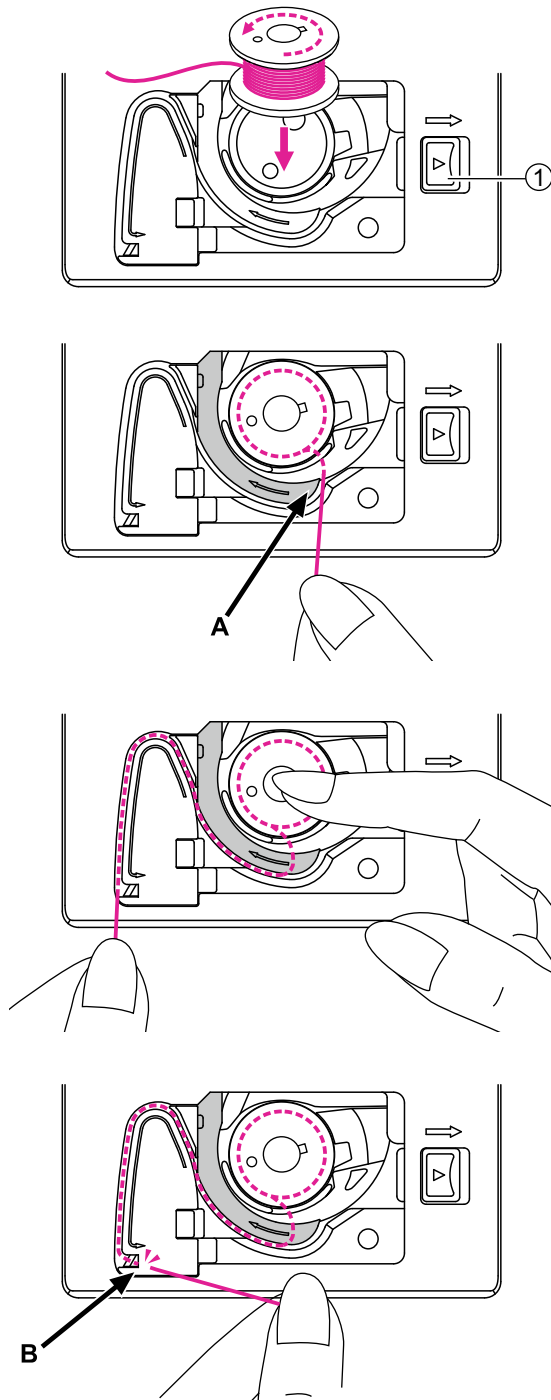

Threading the upper thread

Please following the number order and see the corresponding illustrations below. It is important to carry out the threading correctly to get a quality sewing. Otherwise several problems will occur.

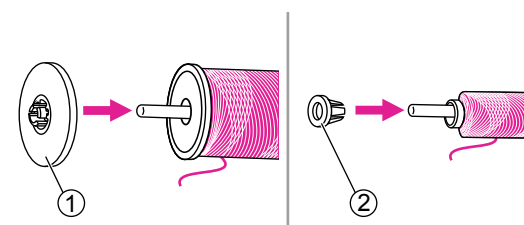
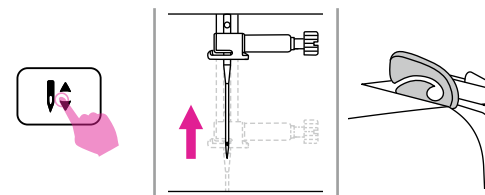
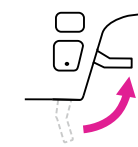
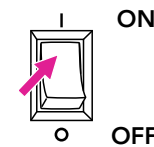
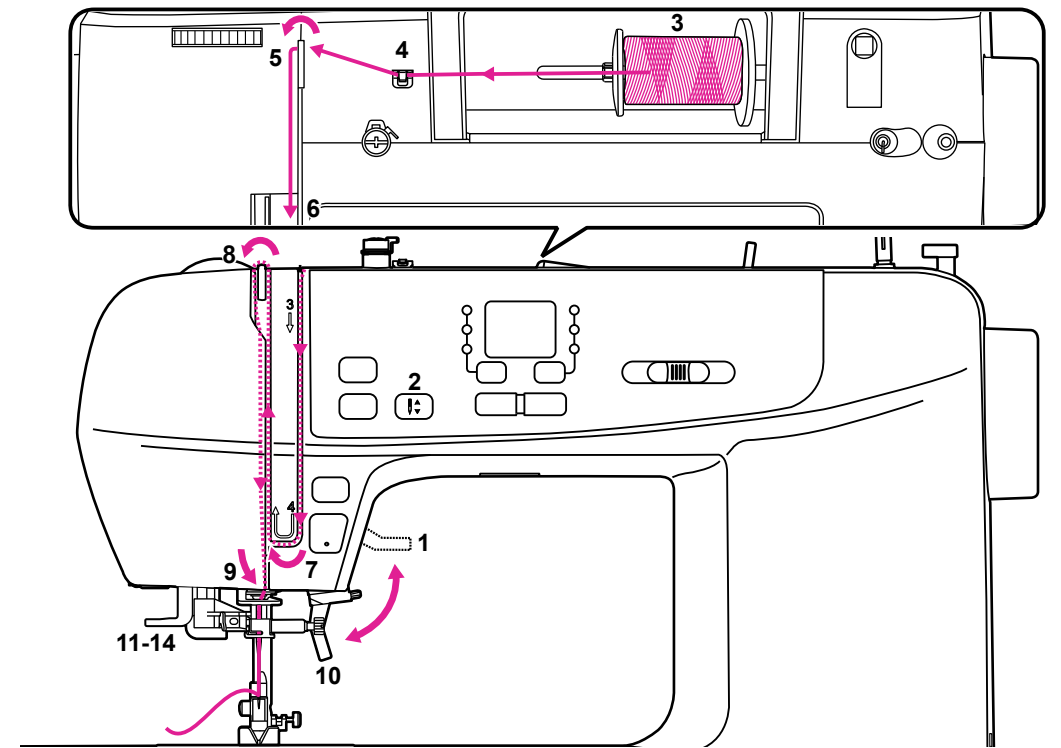

1. Turn the power switch to on ("I"). Raise the presser foot lifter.

2. Press the needle up/down button to bring the needle and take-up lever to highest position.

3. Place the thread and spool holder onto the spool pin. For better sewing quality, choose a proper size of the spool holder for the thread and attach it next to the thread.

- ① Large spool holder
- ② Small spool holder

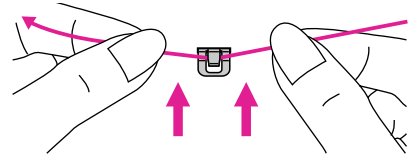

4. Draw the thread from the spool and place the thread in between the upper thread guide.

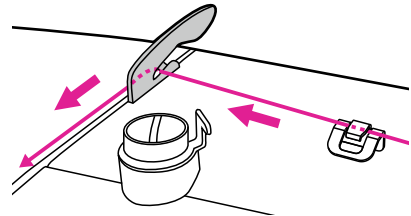

5. Guide the thread ahead and pull the thread through the pre-tension spring as illustrated.

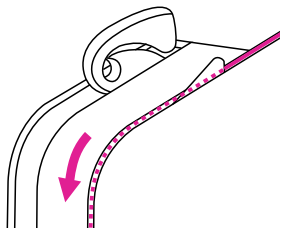

6. Continue to guide the thread into the silver discs to keep the thread in proper tension.

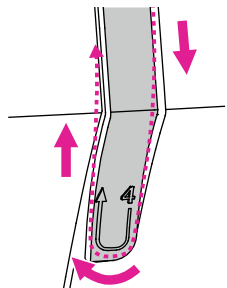

7. Pass the thread under the take-up spring then pull it upwards as arrow marks illustrated.

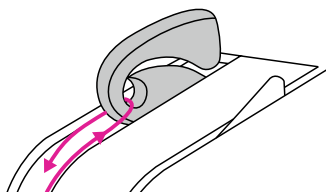

8. Pull the thread to the top then pass the thread through the slotted eye of the take-up lever. Guide the thread down afterwards.

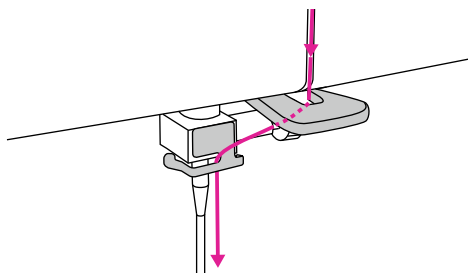

9. Pass the thread behind the flat, horizontal thread guide. Use the needle threader to thread the needle.

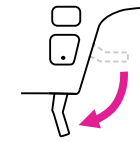

10. Lower the presser foot lifter.

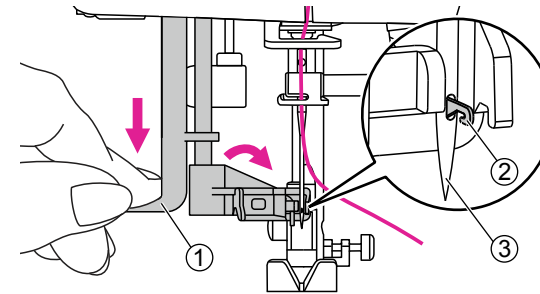

11. Pull down the lever to the very bottom. When heard a "click" sound, it will be on the right position to do the needle threading and the hook pin passes through the needle eye.

- ① Lever
- ② Hook pin
- ③ Needle

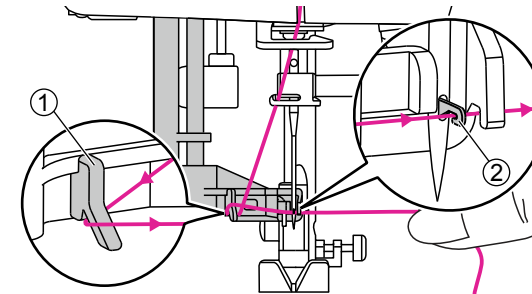

12. Pass the thread around the thread guide. Take the thread in front of the needle and make sure it is under the hook pin.

- ① Thread guide
- ② Hook pin

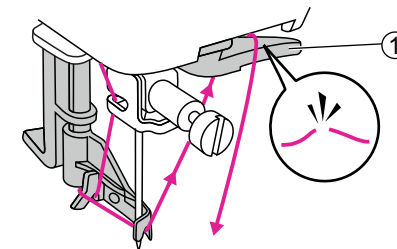

13. To cut the excess thread, take thread end and gently slip it over the thread cutter located on the right of the needle.

- ① Thread cutter

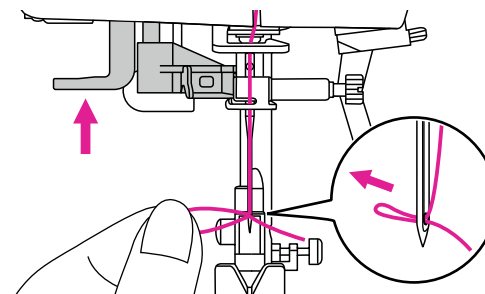

14. Raise the lever, the hook will rotate and pass the thread through the needle eye to form a loop.

Pull the thread through the needle eye to finish threading.

Note

Your machine is threaded and ready for sewing, follow the instructions on "Starting to sew" chapter to start sewing.

Bringing up the bobbin thread

When sewing gathering or smocking stitch, bring up the bobbin thread first as below instruction.

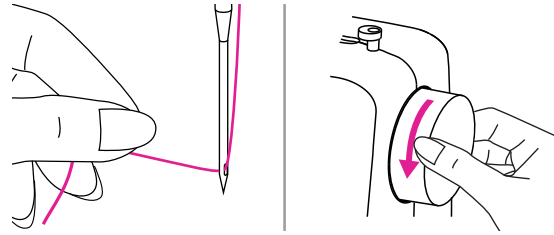

Hold the upper thread with your left hand. Turn the handwheel towards you (counter-clockwise) to lower the needle down below the needle plate then raise it to bring the bobbin thread up.

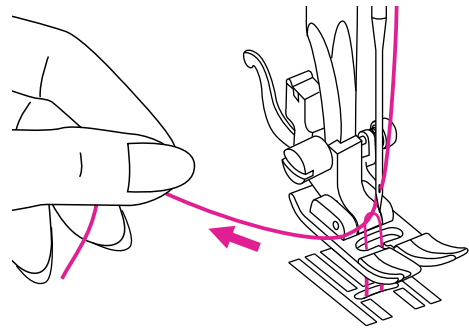

Gently pull on the upper thread to bring the bobbin thread up through the needle plate hole. The bobbin thread will come up in a loop.

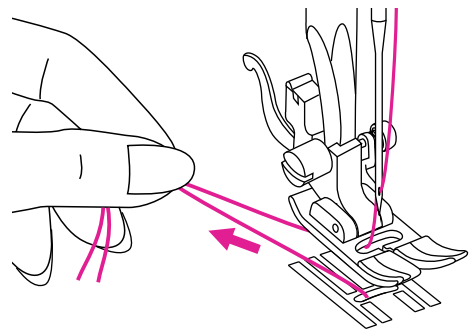

Pull both threads to the back under the presser foot.

Replacing the needle

Change the needle regularly, especially when it shows signs of wear or if it causes problems.

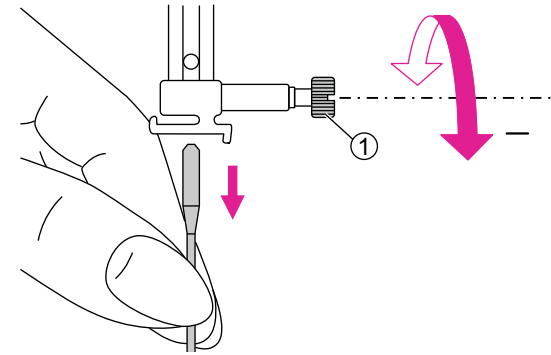

Attention
Turn the power switch to off ("O") when carrying out below operations!

Turn the handwheel toward you to raise the needle then loosen the needle clamp screw to remove the needle.

① Needle clamp screw

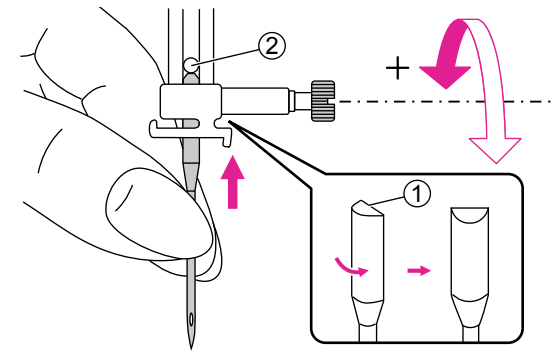

When inserting a new needle, keep the flat side of the shaft to the back.

Push the needle into the clamp until it touches the pin and stops. Then secure it by tightening the needle clamp screw.

① Flat side of the shaft
② Pin

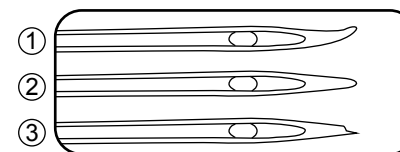
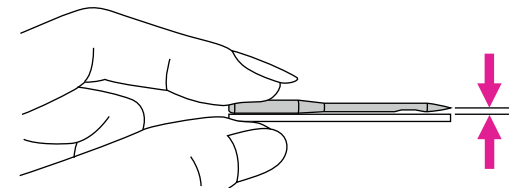

Needles must be in perfect condition.



Problems can occur with:

① Bent needles
② Blunt needles
③ Damaged points

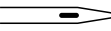
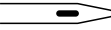
Matching needle/fabric/thread

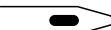
| NEEDLE SIZE | FABRICS | THREAD |
|---|--|---|
| 65/9 - 75/11  | Lightweight fabrics- thin cottons, voile, serge, silk, muslin, Qiana, interlocks, cotton knits, tricot, jerseys, crepes, woven polyester, shirt & blouse fabrics. | Light-duty thread in cotton, nylon, polyester or cotton wrapped polyester. |
| 80/12  | Medium weight fabrics- cotton, satin, kettleclote, sailcloth, double knits, lightweight woolens. | Most threads sold are medium size and suitable for these fabrics and needle sizes. Use polyester threads on synthetic materials and cotton on natural woven fabrics for best results. Always use the same thread on top and bottom. |
| 90/14  | Medium weight fabrics- cotton duck, woolen, heavier knits, terrycloth, denims. | |
| 100/16  | Heavyweight fabrics- canvas, woolens, outdoor tent and quilted fabrics, denims, upholstery material (light to medium). | |

Note

- In general, fine threads and needles are used for sewing fine fabrics, thicker threads and needles are used for sewing heavy fabrics.
- Always test thread and needle size on a small piece of fabric which will be used for actual sewing.
- Use the same thread for needle and bobbin.
- Use a stabilizer or place a backing for fine or stretchy fabrics, and select the correct presser foot.
- It is recommended that a 90/14 needle should be used when embroidering on heavyweight fabrics or stabilizing products (for example, denim, puffy foam, etc.). A 75/11 needle may bend or break, which could result in injury.
- For transparent nylon thread, always use needle 90/14 - 100/16. The same thread is usually used for the bobbin thread and upper threading.
- For good quality embroidery designs, recommend to use a 75/11 needle when embroidering.

Changing the presser foot

⚠ Attention

Turn the power switch to off ("O") when carrying out any of the operations below!

❖ Remove the presser foot

Raise the presser foot lifter. Press the back lever to release the presser foot.

- ① Lever

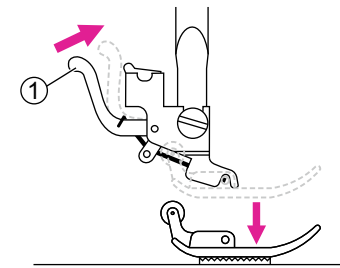

❖ Attach the presser foot

Lower the presser foot lifter until the cut-out meets the pin.

The presser foot will attach to the presser foot holder automatically.

- ① Cut-out
② Pin

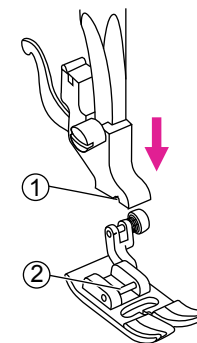

❖ Remove and insert the presser foot holder

Raise the presser foot lifter. Align the presser foot holder with the lower left side of the presser bar. Hold the presser foot holder, then tighten the screw using the enclosed screwdriver.

- ① Presser foot bar
② Presser foot holder

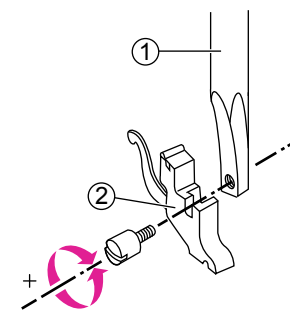

❖ Insert the edge/quilting guide

Insert the edge/quilting guide in the slot as illustrated. Adjust the needed width according to your sewing applications.

- ① Slot
② Edge/quilting guide

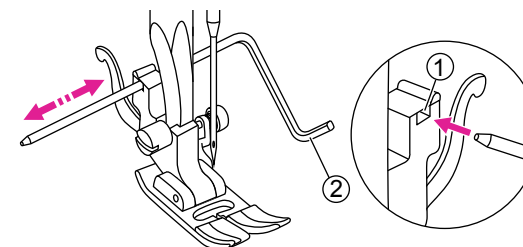

Replacing the needle plate

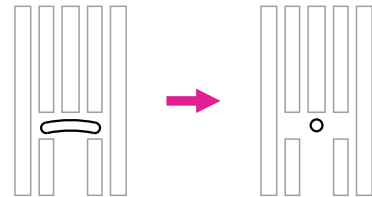
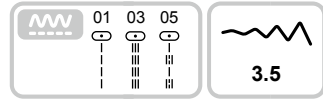

⚠ Attention
Turn the power switch to off ("O").

Only specific straight stitches are applicable while using straight stitch needle plate. (stitch pattern 01 & 03 & 05)

The straight stitch plate is recommended for embroidery mode for better embroidery quality. It can be also used for straight stitches in middle needle position in normal sewing mode.

The particular design of smaller central hole can give a better support of the fabric during straight stitch sewing.

Thus, the fabric can be prevented from being pulled down into bobbin/hook area, especially in the beginning or end of a seam.

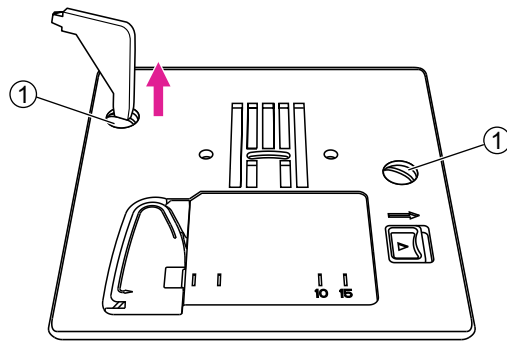

Remove the needle, presser foot and presser foot holder.

Remove the screws on the needle plate then remove the needle plate.

① Screws

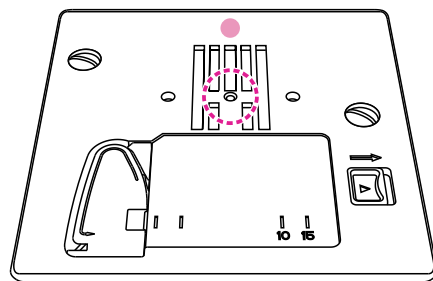

Change the straight stitch plate and tighten the screws.

To raise or drop the feed dogs

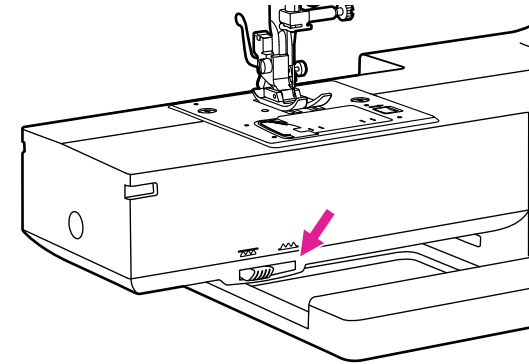

The drop feed lever can be seen on the base at the front side of the sewing machine.

Sliding the drop feed lever to lower or raise the feed dogs. When lever is in raised position, the feed dog will arise automatically when you are sewing.

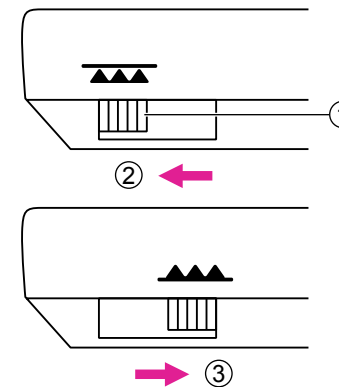

- ① Drop feed lever
- ② Lowered position
- ③ Raised position

Note
When you finish the work, (e.g. button sewing, free motion darning, embroidery and monogramming), please move the drop feed lever to raised position for general sewing purpose.

Adjusting the presser foot pressure

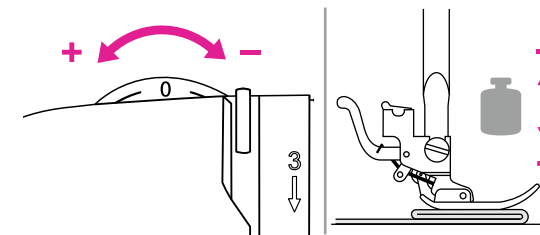

The presser foot pressure dial is on the top left of the face plate.

The presser foot pressure of the machine has been pre-set and requires no particular adjustment for general sewing.

Basic presser foot pressure setting: "0".

For sewing with very thin fabric, reduce the pressure by turning the knob clockwise (-1, -2, -3) and for heavy fabric, increase the pressure by turning it counter-clockwise (+1, +2).

Thread tension

Proper tension setting is important for sewing. There is no single tension setting appropriate for all the stitch functions and fabrics.

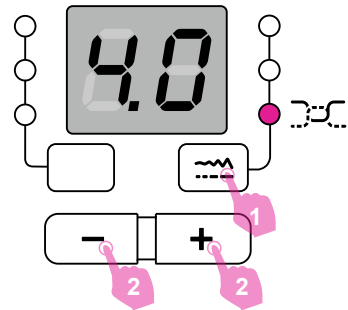

Basic thread tension setting: "4".

1. Press the stitch adjustment button to change to the thread tension mode.
2. When the tension light is on, the upper thread tension can be adjusted.

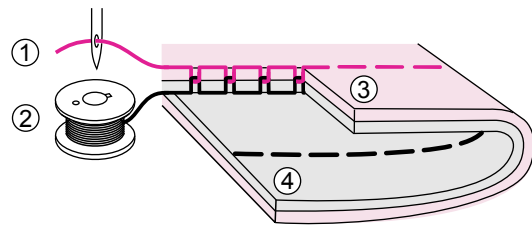

Normal thread tension for straight stitch sewing.

- ① Upper thread
- ② Bobbin thread
- ③ Surface
- ④ Wrong side

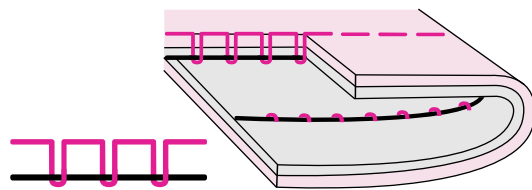

Thread tension is too loose for straight stitch sewing. To increase the tension, press the "+" button.

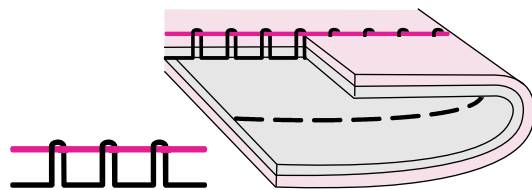

Thread tension is too tight for straight stitch sewing. To reduce the tension, press the "-" button.

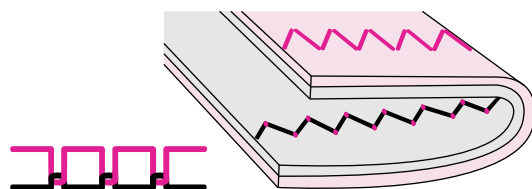

Normal thread tension for zig zag and decorative sewing.

For all decorative sewing you will always obtain a nicer stitch and less fabric puckering.

Correct thread tension is when a small number of the upper thread appears on the bottom side of fabric.

Instruction

Operation buttons

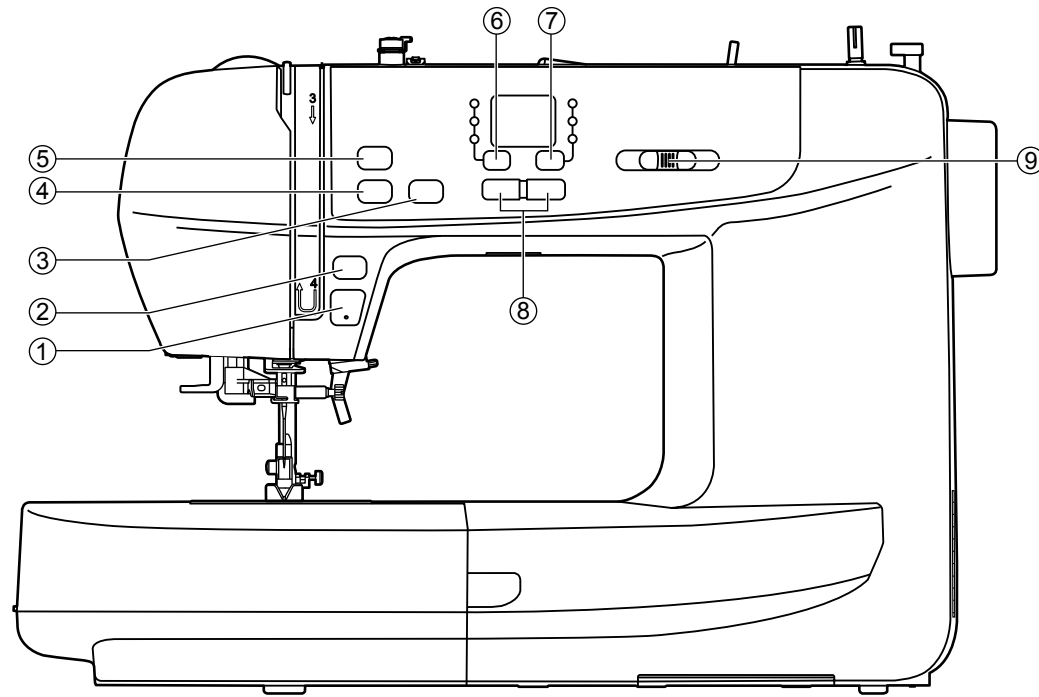

1. Start/stop button

Long press the start/stop button to start machine running. Press the start/stop button again to stop machine. The machine rotates slowly at the beginning of the sewing.

The sewing speed can be controlled by the speed adjustment slider.

This way you may operate the machine without foot control.



2. Reverse button

When the A group patterns 01-06 are selected, the machine will sew reverse at a low speed if the reverse button is pressed. The machine will sew forward after the button is released.

When the A group patterns 07-19, 28-55 and B group patterns 01-65 are selected, the machine will immediately sew 3 locking stitches when the reverse button is pressed, then automatically stop.



3. Needle up/down position button

In sewing mode, with the needle up/down position button, you decide whether the needle stops in the highest or in the lowest position (i.e. in the fabric) when you stop sewing.

Note

During sewing, press the needle up/down button, the machine will stop automatically.



4. Tread cutter button

Press this button after finishing sewing and the machine will trim the thread.



5. Auto-lock button

When machine is not sewing: Press the auto lock button, machine will sew 3 stitches in the same position then stop.

During machine is sewing: When A group patterns 01-06 are selected and the auto-lock button is pressed, the machine will sew 3 locking stitches. Then it will stop automatically.

During machine is sewing: When A group patterns 07-19, 28-55 and B group patterns 01-65 are selected and the auto-lock button is pressed, the machine will sew 3 locking stitches at the end of the current pattern. Then it will stop automatically. The function will be cancelled if you press the button once again or select another pattern.

In embroidery mode, press this button to move the embroidery carriage to left side, and it will be easier for you to change the thread. Press the button again, the embroidery carriage will be back to the original position.

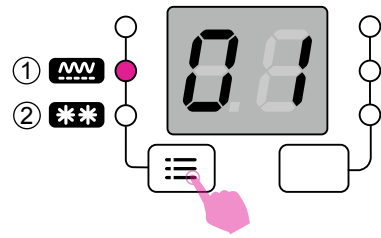

6. Group switch button (In sewing mode)

Press the group switch button to change to the A group patterns or B group patterns mode.

- ① A group patterns
- ② B group patterns

For details, refer to "stitch chart".

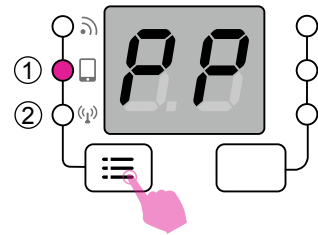

6.1 Connection mode switch button (In embroidery mode)

Press the connection mode switch button to change to the point-to-point mode or router mode.

- ① Point-to-point mode (PP)
- ② Router mode (AP)



6.2 Sound button

Buzzer turn off:

In sewing mode, press the sound button for 2 seconds and when you hear the machine delivering a short beep, the sound will be turned off.

Buzzer turn on:

In sewing mode, when machine is in silent mode, press the button for 2 seconds and it will deliver two short beeps to remind you that the sound is turned on now.

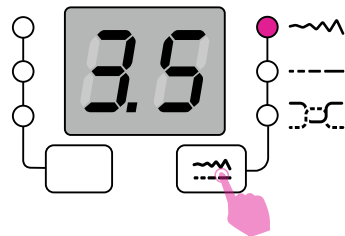

7. Stitch adjustment button

In sewing mode, press the stitch adjustment button to change to the stitch length, stitch width or thread tension mode.

In embroidery mode, press the stitch adjustment button, when the tension light is on, the embroidery thread tension can be adjusted.

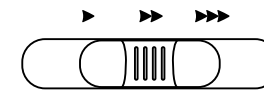
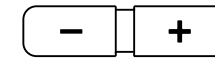

8. Value setting buttons

The +/- button can modify the values for sewing. (stitch number/ stitch length/ stitch width/ thread tension)

9. Speed adjustment slider

The speed adjustment slider can control the sewing speed. To increase the speed, slide the lever to the right. To decrease the sewing speed, slide the lever to the left.

Selecting stitch

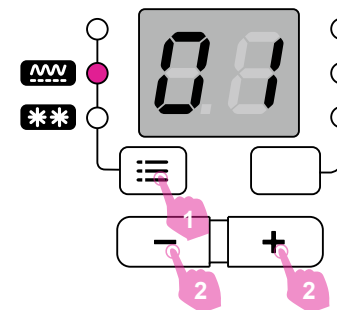

Select the desired stitch from those shown on the stitch pattern plate.

1. Press the group switch button to change to the A group patterns or B group patterns mode.
2. When the group pattern light is on, the +/- buttons can be used to select the pattern number needed; press the "+" button to select the next pattern number and press the "-" button to select the previous pattern number.

When the +/- button is pressed and held down, the numbers will change continuously for quick selection.

Altering the stitch length & width

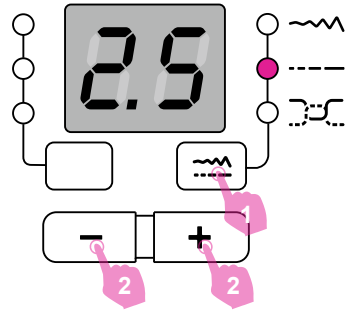

❖ Altering the stitch length

When you select a stitch, the machine will automatically set the recommended stitch length values which will be shown on the LED screen.

1. Press the stitch adjustment button to change to the stitch length mode.
2. For a shorter stitch length, press the "-" button. For a longer stitch length, press the "+" button.

Different stitches will have different length limitation. When the number is set back at its default value, the screen will blink.

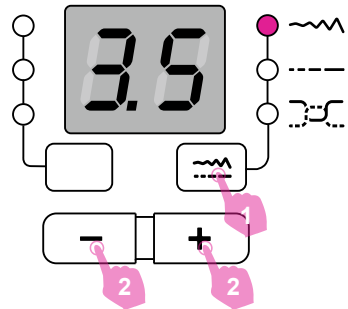
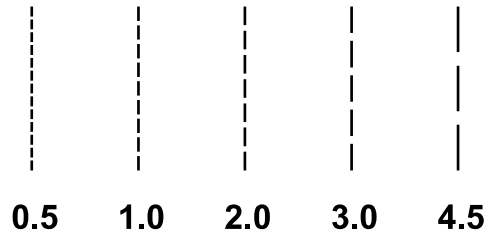

❖ Altering the stitch width

When you select a stitch, the machine will automatically set the recommended stitch width values which will be shown on the LED screen.

1. Press the stitch adjustment button to change to the stitch width mode.
2. For a narrower stitch, press the "-" button. For a wider stitch, press the "+" button.



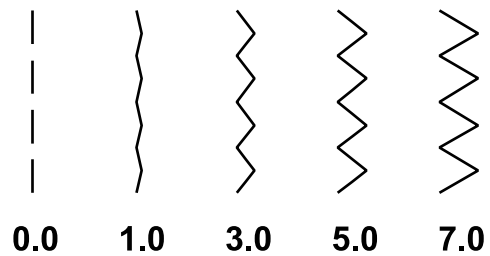















































Different stitches will have different width limitation. When the number is set back at its default value, the screen will blink.







Stitch Chart









































Stitch chart

























❖ A Group patterns

| Stitch Pattern | | Width(mm) | | Length(mm) | | Presser Foot | Fuctions | | | |
|----------------|------------------|---|---|---------------|---------|-----------------|----------|-----------|---|---|
| | | Auto | Manual | Auto | Manual | | Reverse | Auto-lock | | |
| Utility | 01 |  | 3.5 | 0.0~7.0 | 2.5 | 0.0~5.0 | T | * | * | |
| | 02 |  | 0.0 | 0.0~7.0 | 2.5 | 0.0~5.0 | T | * | * | |
| | 03 |  | 3.5 | 0.0~7.0 | 2.5 | 1.0~3.0 | T | * | * | |
| | 04 |  | 3.5 | 1.0~6.0 | 2.5 | 1.0~3.0 | T | * | * | |
| | 05 |  | 3.5 | 0.0~7.0 | 2.5 | 1.5~3.0 | T | * | * | |
| | 06 |  | 5.0 | 0.0~7.0 | 2.0 | 0.3~1.0 1.0~4.5 | T | * | * | |
| | 07 |  | 5.0 | 2.0~7.0 | 1.0 | 0.3~1.0 1.0~4.5 | T | * | * | |
| | 08 |  | 5.0 | 2.5~7.0 | 2.5 | 1.0~3.0 | A | * | * | |
| | 09 |  | 5.0 | 3.5~7.0 | 2.5 | 1.0~3.0 | E | * | * | |
| | 10 |  | 5.0 | 3.5~7.0 | 2.5 | 1.0~3.0 | T | * | * | |
| | 11 |  | 5.0 | 2.5~7.0 | 2.5 | 1.0~3.0 | T | * | * | |
| | 12 |  | 5.0 | 2.5~7.0 | 2.5 | 1.0~3.0 | T | * | * | |
| | 13 |  | 3.5 | 1.0~7.0 | 2.0 | 0.5~4.5 | F | * | * | |
| | 14 |  | 3.5 | 1.0~7.0 | 2.0 | 0.5~4.5 | T | * | * | |
| | 15 |  | 3.5 | 2.5~7.0 | 1.0 | 0.5~4.5 | F | * | * | |
| | 16 |  | 3.5 | 2.5~7.0 | 1.0 | 0.5~4.5 | T | * | * | |
| | 17 |  | 5.0 | 2.5~7.0 | 2.5 | 1.0~3.0 | T | * | * | |
| | 18 |  | 7.0 | 2.5~7.0 | 2.5 | 1.0~3.0 | A | * | * | |
| | 19 |  | 5.0 | 2.5~7.0 | 2.5 | 1.0~3.0 | A | * | * | |
| Buttonhole | 20 |  | 5.0 | 3.0~7.0 | 0.4 | 0.3~1.0 | D | | | |
| | 21 |  | 5.0 | 3.0~5.5 | 0.4 | 0.3~1.0 | D | | | |
| | 22 |  | 7.0 | 5.5~7.0 | 0.4 | 0.3~1.0 | D | | | |
| | 23 |  | 5.0 | 3.0~5.5 | 0.4 | 0.3~1.0 | D | | | |
| | 24 |  | 5.0 | 3.0~5.5 | 0.4 | 0.3~1.0 | D | | | |
| | 25 |  | 6.0 | 3.0~7.0 | 1.0 | 1.0~2.0 | D | | | |
| Eyelet | 26 |  | 7.0 | 7.0, 6.0, 5.0 | — | — | A | | | |
| Button sewing | 27 |  | 3.5 | 2.5~4.5 | — | — | H | | | |
| Satin | 28 |  | 7.0 | 2.5~7.0 | 0.4 | 0.3~1.0 | A | * | * | |
| | 29 |  | 7.0 | 2.5~7.0 | 0.4 | 0.3~1.0 | A | * | * | |
| | 30 |  | 7.0 | 2.5~7.0 | 0.4 | 0.3~1.0 | A | * | * | |
| | 31 |  | 7.0 | 2.5~7.0 | 0.4 | 0.3~1.0 | A | * | * | |
| | 32 |  | 7.0 | 2.5~7.0 | 0.4 | 0.3~1.0 | A | * | * | |
| | 33 |  | 7.0 | 2.5~7.0 | 0.4 | 0.3~1.0 | A | * | * | |
| | 34 |  | 7.0 | 2.5~7.0 | 0.4 | 0.3~1.0 | A | * | * | |
| | 35 |  | 7.0 | 2.5~7.0 | 0.4 | 0.3~1.0 | A | * | * | |
| | 36 |  | 7.0 | 2.5~7.0 | 0.4 | 0.3~1.0 | A | * | * | |
| | 37 |  | 7.0 | 2.5~7.0 | 0.4 | 0.3~1.0 | A | * | * | |
| | 38 |  | 7.0 | 2.5~7.0 | 0.4 | 0.3~1.0 | A | * | * | |
| | 39 |  | 7.0 | 2.5~7.0 | 0.4 | 0.3~1.0 | A | * | * | |
| | 40 |  | 7.0 | 2.5~7.0 | 0.4 | 0.3~1.0 | A | * | * | |
| | 41 |  | 7.0 | 2.5~7.0 | 0.4 | 0.3~1.0 | A | * | * | |
| | 42 |  | 7.0 | 2.5~7.0 | 0.4 | 0.3~1.0 | A | * | * | |
| | 43 |  | 7.0 | 2.5~7.0 | 0.4 | 0.3~1.0 | A | * | * | |
| | 44 |  | 7.0 | 2.5~7.0 | 0.4 | 0.3~1.0 | A | * | * | |
| | Decorative satin | 45 |  | 7.0 | 2.5~7.0 | 1.5 | 1.5~3.0 | A | * | * |
| | | 46 |  | 7.0 | 2.5~7.0 | 1.5 | 1.5~3.0 | A | * | * |
| | | 47 |  | 7.0 | 2.5~7.0 | 1.0 | 1.0~2.0 | A | * | * |
| 48 | |  | 7.0 | 2.5~7.0 | 1.5 | 1.5~3.0 | A | * | * | |
| 49 | |  | 7.0 | 3.5~7.0 | 1.5 | 1.0~3.0 | A | * | * | |
| 50 | |  | 7.0 | 4.0~7.0 | 1.5 | 1.5~3.0 | A | * | * | |

| Stitch Pattern | | Width(mm) | | Length(mm) | | Presser Foot | Fuctions | | |
|----------------|----|---|--------|------------|--------|--------------|----------|-----------|---|
| | | Auto | Manual | Auto | Manual | | Reverse | Auto-lock | |
| Cross | 51 |  | 5.0 | 2.5~7.0 | 2.5 | 1.0~3.0 | A | * | * |
| | 52 |  | 6.0 | 3.0~7.0 | 1.0 | 1.0~3.0 | A | * | * |
| | 53 |  | 6.0 | 3.0~7.0 | 1.0 | 1.0~3.0 | A | * | * |
| | 54 |  | 4.0 | 3.0~7.0 | 1.0 | 1.0~3.0 | A | * | * |
| | 55 |  | 6.0 | 3.0~7.0 | 1.5 | 1.0~3.0 | A | * | * |

❖ B Group patterns

| Stitch Pattern | | Width(mm) | | Length(mm) | | Presser Foot | Fuctions | | |
|----------------|----|---|--------|------------|--------|--------------|----------|-----------|---|
| | | Auto | Manual | Auto | Manual | | Reverse | Auto-lock | |
| Quilt | 01 |  | 5.0 | 2.5~7.0 | 2.0 | 1.0~4.5 | T | * | * |
| | 02 |  | 4.0 | 2.5~7.0 | 2.0 | 1.0~4.5 | T | * | * |
| | 03 |  | 3.5 | 2.5~7.0 | 2.5 | 1.5~3.0 | T | * | * |
| | 04 |  | 3.5 | 2.5~7.0 | 2.5 | 1.5~3.0 | T | * | * |
| | 05 |  | 3.5 | 2.5~7.0 | 2.5 | 1.5~3.0 | T | * | * |
| | 06 |  | 3.5 | 2.5~7.0 | 2.5 | 1.5~3.0 | T | * | * |
| | 07 |  | 4.0 | 2.5~7.0 | 2.5 | 1.5~3.0 | A | * | * |
| | 08 |  | 4.0 | 2.5~7.0 | 2.5 | 1.5~3.0 | A | * | * |
| | 09 |  | 3.5 | 2.5~7.0 | 2.5 | 1.5~3.0 | T | * | * |
| | 10 |  | 6.0 | 3.0~7.0 | 2.0 | 1.0~4.5 | T | * | * |
| | 11 |  | 6.0 | 3.0~7.0 | 2.0 | 1.0~4.5 | T | * | * |
| | 12 |  | 7.0 | 3.0~7.0 | 1.5 | 1.0~4.5 | T | * | * |
| | 13 |  | 6.0 | 3.0~7.0 | 2.0 | 1.0~3.0 | T | * | * |
| | 14 |  | 5.0 | 3.0~7.0 | 2.0 | 1.0~3.0 | T | * | * |
| | 15 |  | 5.0 | 2.5~7.0 | 2.0 | 1.0~3.0 | T | * | * |
| | 16 |  | 6.0 | 3.5~7.0 | 1.5 | 1.0~3.0 | T | * | * |
| | 17 |  | 5.0 | 3.5~7.0 | 1.5 | 1.5~3.0 | A | * | * |
| | 18 |  | 5.0 | 2.5~7.0 | 1.0 | 1.0~4.5 | T | * | * |
| | 19 |  | 6.0 | 3.0~7.0 | 2.0 | 1.0~3.0 | T | * | * |
| | 20 |  | 7.0 | 2.5~7.0 | 1.5 | 1.0~3.0 | A | * | * |
| Decorative | 21 |  | 6.0 | 2.5~7.0 | 1.5 | 1.0~3.0 | T | * | * |
| | 22 |  | 7.0 | 2.5~7.0 | 2.0 | 1.0~3.0 | T | * | * |
| | 23 |  | 5.0 | 2.5~7.0 | 2.0 | 1.0~3.0 | T | * | * |
| | 24 |  | 6.0 | 2.5~7.0 | 3.0 | 1.0~3.0 | T | * | * |
| | 25 |  | 5.0 | 4.0~7.0 | 2.5 | 1.5~3.0 | A | * | * |
| | 26 |  | 6.0 | 3.5~7.0 | 2.0 | 1.5~3.0 | A | * | * |
| | 27 |  | 5.0 | 2.5~7.0 | 2.5 | 1.0~3.0 | A | * | * |
| | 28 |  | 6.0 | 3.5~7.0 | 2.0 | 1.5~3.0 | A | * | * |
| | 29 |  | 6.0 | 4.5~7.0 | 1.5 | 1.0~3.0 | A | * | * |
| | 30 |  | 5.0 | 3.0~7.0 | 2.0 | 2.0~3.0 | A | * | * |
| | 31 |  | 5.0 | 4.0~7.0 | 1.5 | 1.0~3.0 | A | * | * |
| | 32 |  | 7.0 | 2.5~7.0 | 2.0 | 1.0~3.0 | T | * | * |
| | 33 |  | 7.0 | 2.5~7.0 | 2.5 | 1.5~3.0 | T | * | * |
| | 34 |  | 5.0 | 2.5~7.0 | 2.5 | 1.5~3.0 | T | * | * |
| | 35 |  | 5.0 | 2.5~7.0 | 2.5 | 1.5~3.0 | T | * | * |
| | 36 |  | 5.0 | 3.0~7.0 | 3.0 | 1.5~3.0 | A | * | * |
| | 37 |  | 7.0 | 3.0~7.0 | 2.0 | 1.0~3.0 | T | * | * |
| | 38 |  | 7.0 | 4.0~7.0 | 3.0 | 2.0~3.0 | A | * | * |
| | 39 |  | 7.0 | 3.0~7.0 | 2.0 | 1.5~3.0 | A | * | * |
| | 40 |  | 7.0 | 3.5~7.0 | 2.0 | 1.0~3.0 | T | * | * |

| Stitch Pattern | | Width(mm) | | Length(mm) | | Presser Foot | Fuctions | | |
|----------------|----|---|--------|------------|--------|--------------|----------|-----------|---|
| | | Auto | Manual | Auto | Manual | | Reverse | Auto-lock | |
| Decorative | 41 |  | 7.0 | 4.0~7.0 | 2.0 | 2.0~3.0 | A | * | * |
| | 42 |  | 7.0 | 2.5~7.0 | 2.5 | 1.0~4.5 | T | * | * |
| | 43 |  | 7.0 | 2.5~7.0 | 1.5 | 1.0~3.0 | T | * | * |
| | 44 |  | 7.0 | 4.0~7.0 | 2.5 | 2.0~3.0 | A | * | * |
| | 45 |  | 5.0 | 2.5~7.0 | 2.0 | 2.0~3.0 | A | * | * |
| | 46 |  | 7.0 | 3.5~7.0 | 1.0 | 1.0~3.0 | A | * | * |
| | 47 |  | 7.0 | 4.0~7.0 | 3.0 | 2.0~3.0 | A | * | * |
| | 48 |  | 7.0 | 4.0~7.0 | 2.0 | 1.0~3.0 | A | * | * |
| | 49 |  | 7.0 | 3.0~7.0 | 3.0 | 1.0~3.0 | A | * | * |
| | 50 |  | 7.0 | 3.0~7.0 | 2.0 | 1.5~3.0 | A | * | * |
| | 51 |  | 5.0 | 3.5~7.0 | 1.0 | 1.0~3.0 | A | * | * |
| | 52 |  | 5.0 | 4.0~7.0 | 2.0 | 2.0~3.0 | A | * | * |
| | 53 |  | 7.0 | 3.0~7.0 | 2.0 | 1.5~3.0 | A | * | * |
| | 54 |  | 7.0 | 2.5~7.0 | 2.0 | 1.0~3.0 | A | * | * |
| | 55 |  | 7.0 | 2.5~7.0 | 2.5 | 1.5~3.0 | A | * | * |
| | 56 |  | 7.0 | 3.5~7.0 | 2.5 | 1.5~3.0 | T | * | * |
| | 57 |  | 7.0 | 3.0~7.0 | 2.5 | 1.0~3.0 | T | * | * |
| | 58 |  | 7.0 | 2.5~7.0 | 2.0 | 1.5~3.0 | T | * | * |
| | 59 |  | 5.0 | 2.5~7.0 | 2.0 | 1.0~3.0 | T | * | * |
| | 60 |  | 5.0 | 2.5~7.0 | 1.5 | 1.0~3.0 | T | * | * |
| | 61 |  | 5.5 | 2.5~7.0 | 2.0 | 1.5~3.0 | T | * | * |
| | 62 |  | 5.0 | 2.5~7.0 | 2.0 | 1.0~3.0 | T | * | * |
| | 63 |  | 5.0 | 2.5~7.0 | 2.0 | 1.0~3.0 | T | * | * |
| | 64 |  | 5.0 | 3.0~7.0 | 2.0 | 1.0~3.0 | T | * | * |
| | 65 |  | 6.0 | 4.0~7.0 | 2.0 | 2.0~3.0 | A | * | * |

Sewing Basics

Straight stitch

While sewing straight stitches, please use straight stitch plate for better stitch performance.

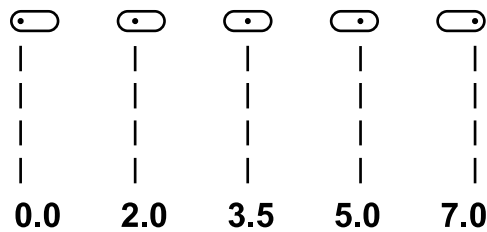
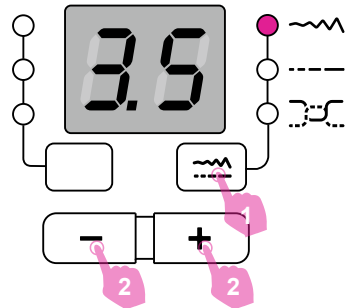
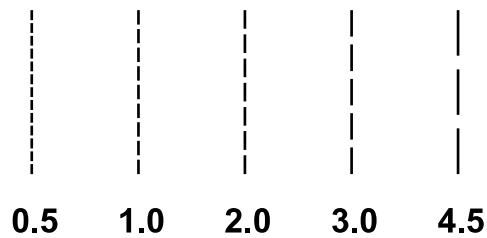
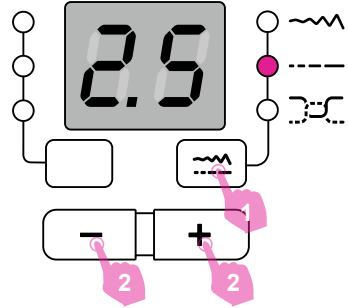
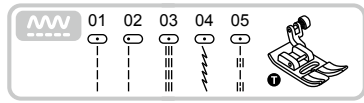

Using the all purpose foot.

Set the pattern as shown in figure.

1. Press the stitch adjustment button to change to the stitch length mode.
2. For a shorter stitch length, press the "-" button. For a longer stitch length, press the "+" button.

Generally speaking, the thicker the fabric, thread and needle, the longer the stitch length should be.

❖ Changing the needle position

The needle position for straight stitches can be changed by adjusting the stitch width.

The pre-set position is "3.5", center position.

1. Press the stitch adjustment button to change to the stitch width mode.
2. Press the "+" button, the needle position will be moved to the right. Press the "-" button, the needle position will be moved to the left.

Zigzag stitch

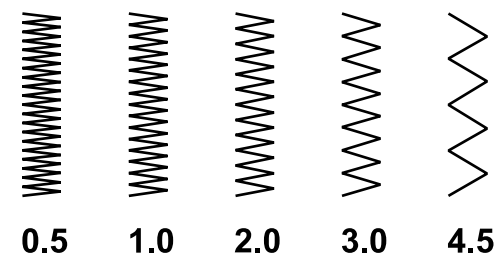
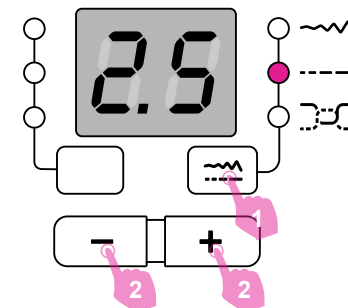
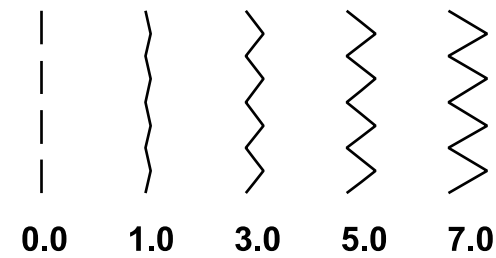
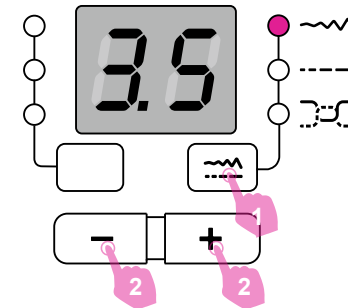

Using the all purpose foot or satin stitch foot.

Set the pattern as shown in figure.

1. Press the stitch adjustment button to change to the stitch width mode.
2. The width can be adjusted as you press the "+" or "-" buttons.

The width can be reduced on these patterns.

1. Press the stitch adjustment button to change to the stitch length mode.
2. The length can be adjusted as you press the "+" or "-" buttons.

Neat zig-zag stitches are usually achieved at "2.5" or below.

Closed up zigzag stitches (close together) are referred to as a satin stitch.

Starting to sew

Make sure you follow the needle/fabric/thread combinations and use the suggested presser foot before sewing.

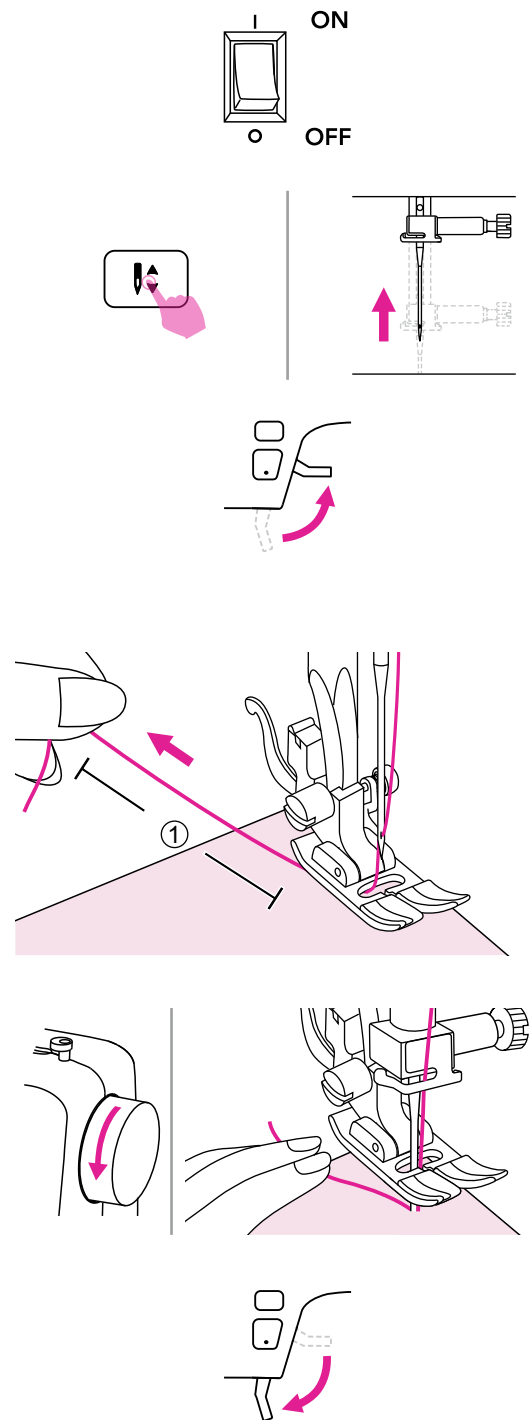

1. Turn the power switch to on ("I").
2. Press the needle up/down button to bring the needle to highest position.
3. Raise the presser foot lifter. Select a stitch.
4. Place the fabric under the presser foot, pass the thread under the presser foot, and then pull out about 10cm of thread toward the rear of the machine.
① 10cm
5. Turn the handwheel toward you (counter-clockwise) to lower the needle into the fabric at the beginning of the stitching.
6. Lower the presser foot lifter.

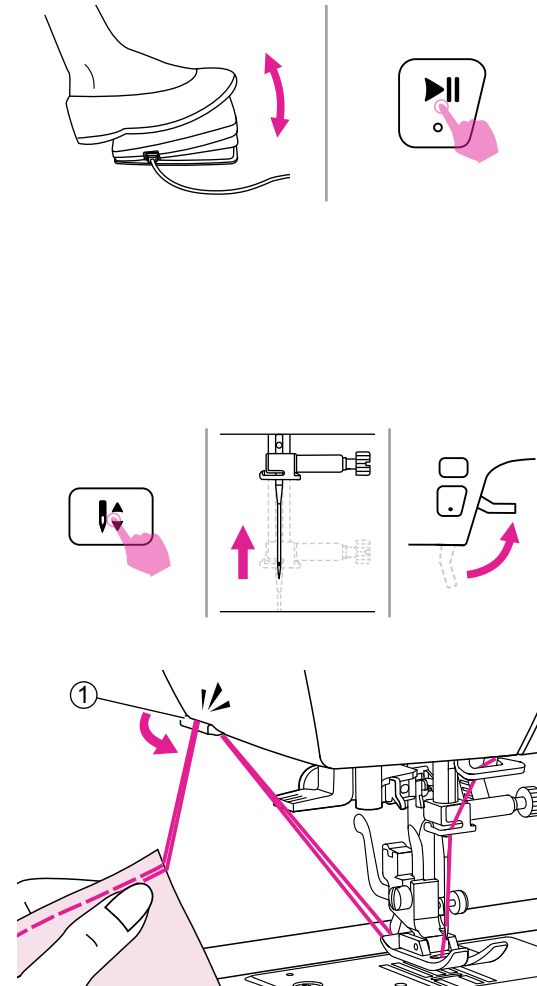

7. Slowly press down the foot control or press the start/stop button to start sewing. Release the foot control or press the start/stop button again to stop the machine.

Note

You can use reverse sewing for back tacking and reinforcing seams by pressing the reverse button. Please refer to "Useful skills" chapter for more information.

8. Press the needle up/down button to raise the needle. Raise the presser foot lifter and remove the fabric.
9. Guide both threads to the side of the face plate and into the thread cutter to cut them.
① Thread cutter

Useful skills

Various ways to achieve better results for your sewing projects are described below. Refer to these tips when sewing your project.

The results depend on types of fabrics and stitches. Please use the same fabric of the project and do a sewing test in advance.

For the trial sewing, use a piece of fabric and thread that are same as those used for your project and check the thread tension and stitch length and width.

Since the results differ depending on types of stitching and layers of fabric sewn, perform the trial sewing under the same conditions that will be used with your project.

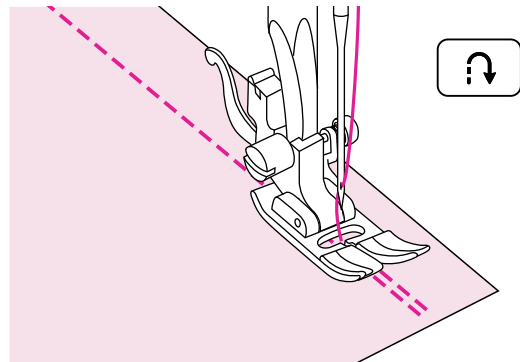

❖ Reverse sewing

Reverse stitching is used to secure the threads at the beginning and at the end of a seam.

Press the reverse button and sew 4-5 stitches.

The machine will sew forward when the button is released.

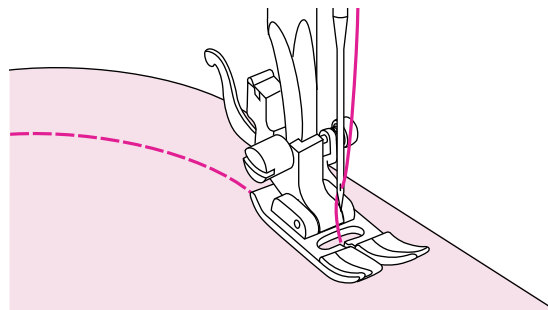

❖ Sewing curves

Slightly change the sewing direction to sew around the curve.

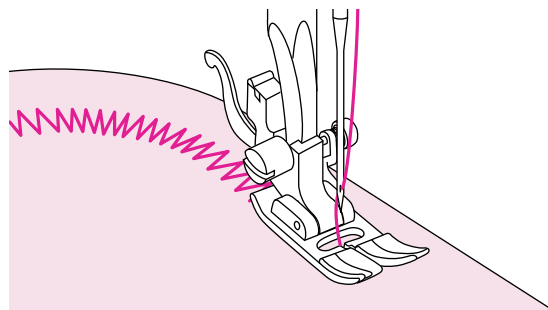

When sewing along a curve while using a zigzag stitch, select a shorter stitch length in order to obtain a finer stitch.

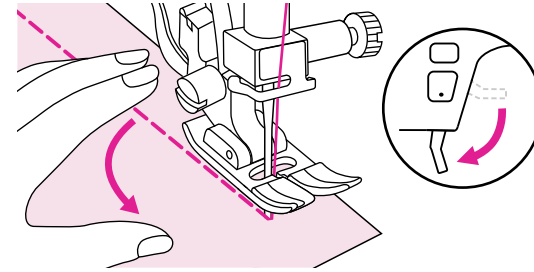

❖ Sewing corners

Stop the sewing machine when you reach a corner.

Lower the needle into the fabric. Raise the presser foot. Use the needle as a pivot and turn the fabric 90°.

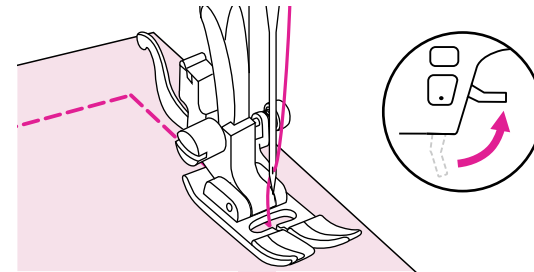

Lower the presser foot and resume sewing.

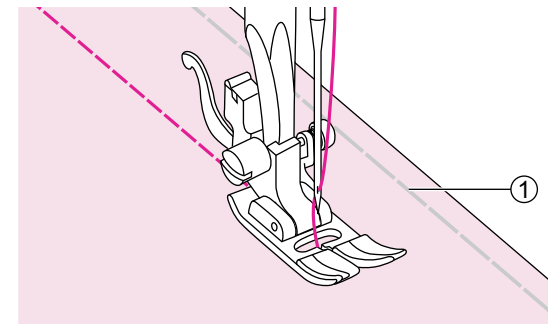

❖ Sewing stretch fabrics

Baste the pieces of fabric together, and then sew without stretching the fabric.

① Basting.

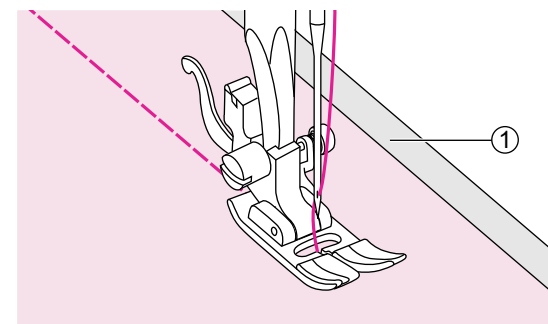

❖ Sewing thin fabrics

When sewing thin fabrics, the stitches may become misaligned or the fabric may not feed correctly. If this occurs, place thin paper or stabilizer material under the fabric and sew it together with the fabric.

When you have finished sewing, tear off any excess paper.

① Stabilizer material or paper

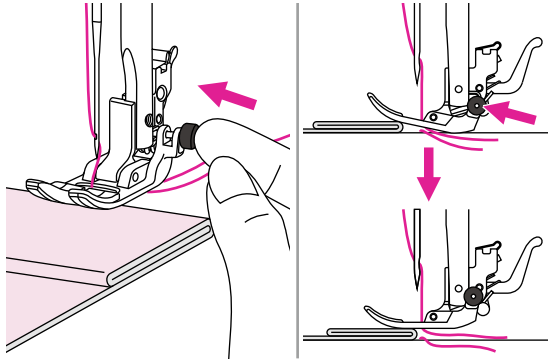

❖ Sewing heavy fabric

The black button on the right side of the presser foot will lock the presser foot in a horizontal position if you push it in before lowering the presser foot.

This ensures even feeding at the beginning of a seam and helps when sewing multiple layers of fabrics such as sewing over seams when hemming jeans.

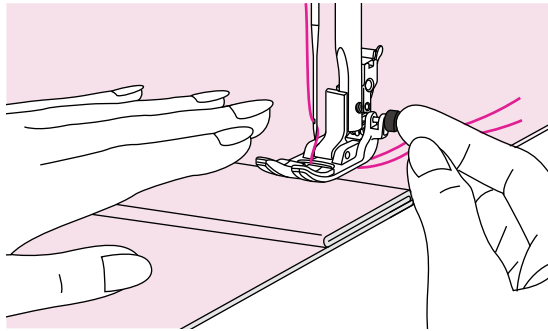

When you reach the point of an increased thickness, lower the needle and raise the presser foot. Press the toe of the foot to the horizontal line and push in the black button, then lower the foot and continue sewing.

The black button releases automatically after sewing few stitches.

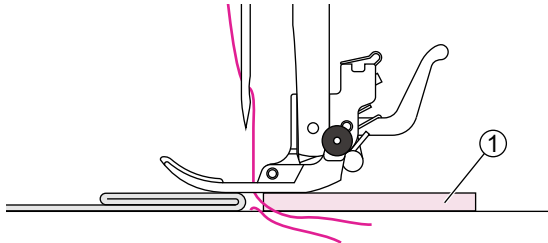

You also can place another piece of fabric with the same thickness at the back of the seam. Or support the presser foot while feeding by hand and sewing toward the folded side.

① Cardboard or thick fabric

Utility Stitches

Stretch stitch

Use this stitch with knitted tricot or other stretchy fabrics. The stitch enables your seam to stretch without breaking the thread.

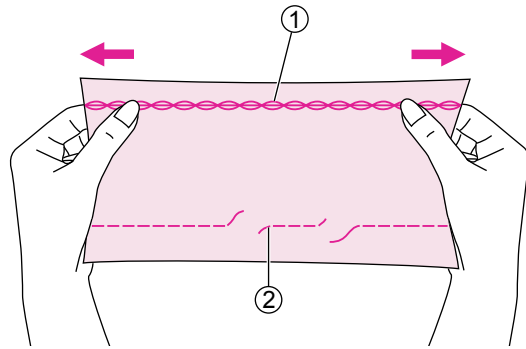

Good for easy to ravel and knit fabrics. It's good for joining durable fabric such as denims.

These stitches can also be used as a decorative top stitches.

- ① Stretch stitch
- ② Straight stitch

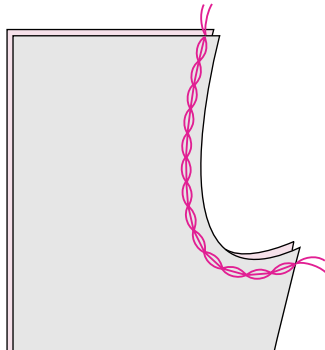
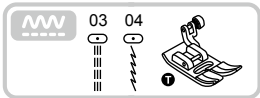

Using the all purpose foot.

❖ Straight stretch stitch

Straight stretch stitch is used to add triple reinforcement to stretch and hardwearing seams.

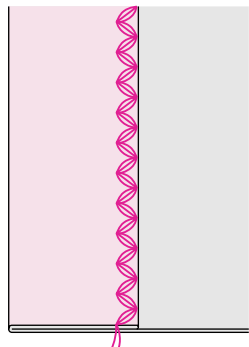
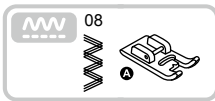

Using the satin stitch foot.

❖ Zigzag stretch stitch

Triple zigzag stretch stitch is suitable for firm fabrics like denim, poplin, etc.

Sewing stretch fabrics and elastic tape

When elastic tape is attached to the cuff or waist of a piece of clothing, the finished dimensions will be that of the stretched elastic tape. Therefore, it is necessary that a suitable length of the elastic tape be used.

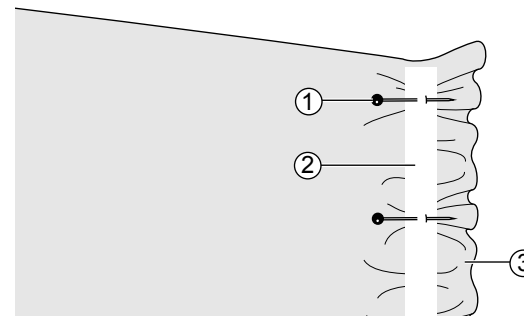

Using the all purpose foot.

Pin the elastic tape to the wrong side of fabric at a few points to make sure that the tape is uniformly positioned on the fabric.

- ① Pin
- ② Elastic tape
- ③ Wrong side

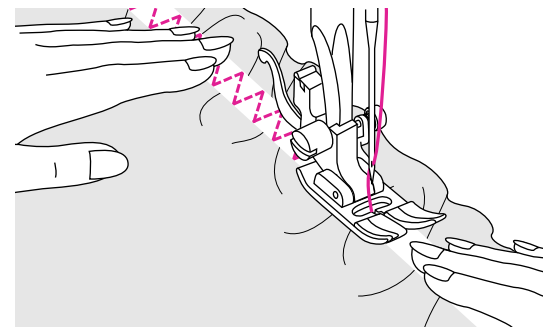

Sew the elastic tape to the fabric while stretching the tape so that it is the same length as the fabric.

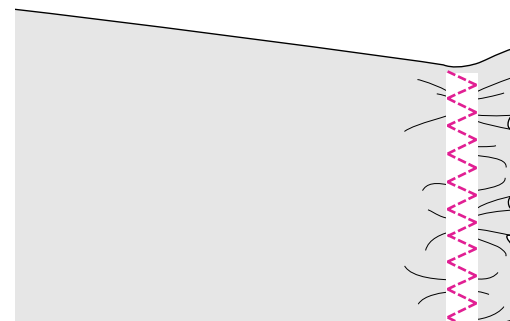

While pulling the fabric behind the presser foot with your left hand, pull the fabric at the pin nearest the front of the presser foot with your right hand.

Note

When sewing, be sure that the needle does not touch any pins, otherwise the needle may bend or break.

Overcasting stitch

Sewing overcasting stitches along the edge of fabric to prevent it from fraying.

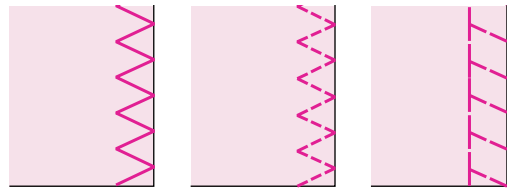
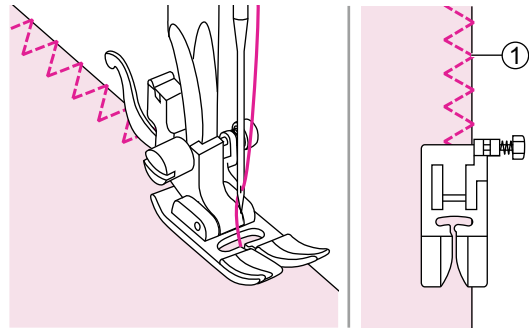
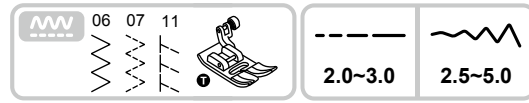

❖ Using the all purpose foot

Attach the all purpose foot.

Sewing the overcasting along the edge of the fabric so that the needle drops over the edge of the fabric on the right side.

- ① Needle drop point

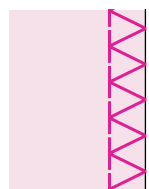
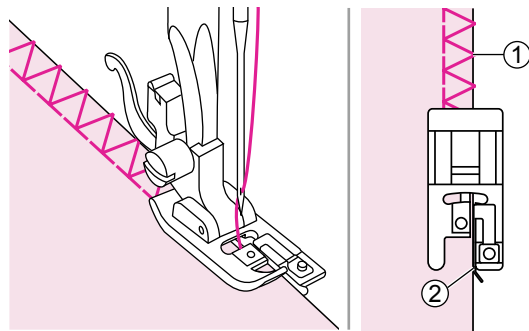

❖ Using the overcasting foot

Attach the overcasting foot.

Sew the fabric with the fabric edge against the guide of the overcasting foot.

- ① Needle drop point
- ② Guide

Blind Hem

Secure the bottom of skirts and pants with a blind hem, this stitch will sew with invisible stitch on the right side of the fabric.

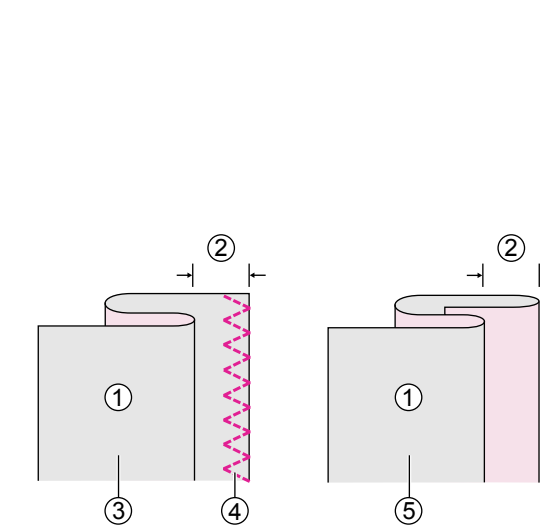
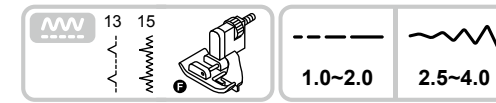

Using the blind hem foot.

- 13: Blind hem/lingerie for firm fabrics.
- 15: Blind hem for stretch fabrics.

Note

Please use the same fabric of the project and do a sewing test in advance.

Fold the fabric as illustrated with the wrong side up.

- ① Wrong side
- ② 5mm
- ③ For heavy weight fabric
- ④ Overcasting stitch
- ⑤ For light/medium weight fabric

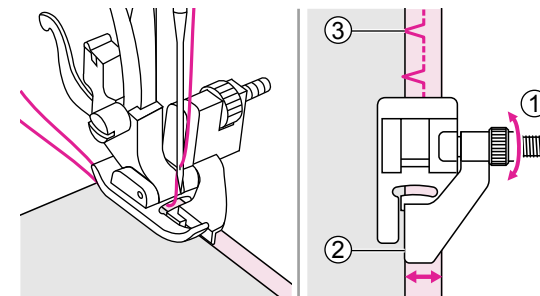

Place the fabric under the foot. Turn the handwheel forwards until the needle swings fully to the left. It should just pierce the fold of the fabric. If it does not, adjust the stitch width accordingly. Adjust the guide by turning the knob so that the guide just rests against the fold.

- ① Knob
- ② Guide
- ③ Needle drop point

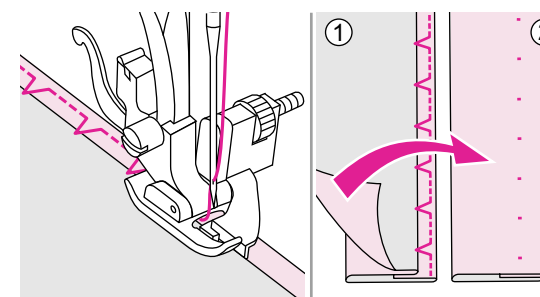

Sew slowly, guiding the fabric carefully along the edge of the guide.

Turn over the fabric.

- ① Wrong side
- ② Right side

Buttonhole stitch

Buttonholes can be adapted to the size of the button.

For stretch fabric or thin fabric, it is recommended to use a stabilizer for a better buttonhole sewing. Slightly reduce upper thread tension to produce better results.

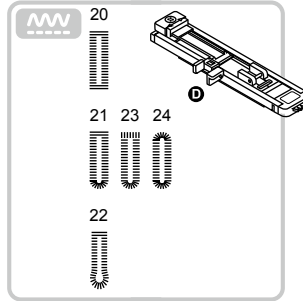

Using the buttonhole foot.

20/21/24: For thin or medium fabric

22: For suits or overcoats

23: For horizontal buttonholes on thick fabrics

Note

Please use the same fabric of the project and do a sewing test in advance.

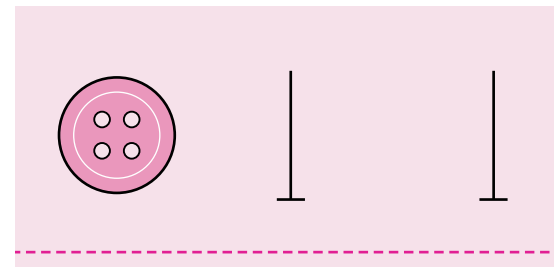

Mark the positions of the buttonhole on the fabric.

The maximum buttonhole length is 3cm. (Total of diameter + thickness of button.)

The size of the buttonhole is determined by the button inserted in the button plate.

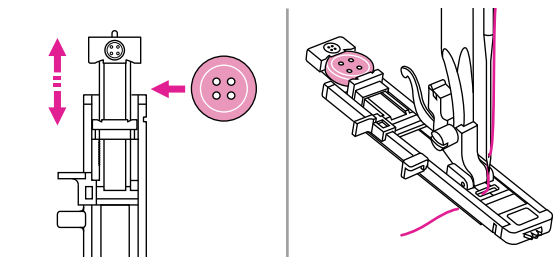

Pull the button holder plate to the back, and place the button in it. Push back the button holder plate against the button to hold it tight.

Attach the buttonhole foot.

The thread should be passed through the hole in the presser foot, then be placed under the foot.

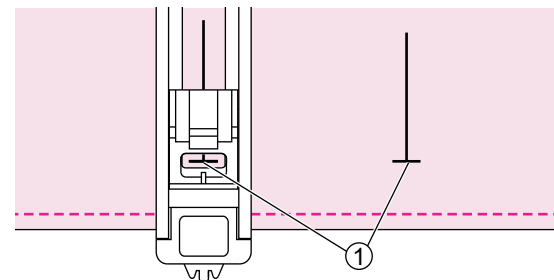

Position the fabric under the presser foot so that the centerline's mark is aligning with the center of the buttonhole foot.

① Starting point

Select the buttonhole stitch. Adjust the stitch width and the stitch length to the desired width and density

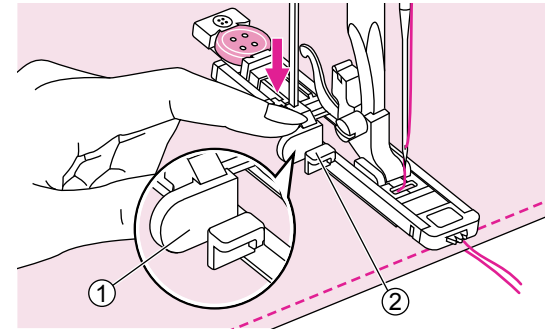

Pull the buttonhole lever all the way down and position it behind the bracket on the buttonhole foot.

- ① Buttonhole lever
- ② Bracket

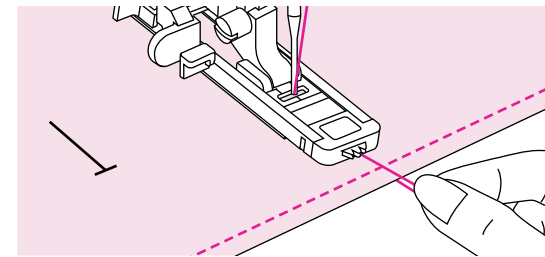

Slightly hold the end of the upper thread and start sewing. Pull two lines together.

Note

Gently feed the fabric by hand.

Before stopping, the machine will automatically sew a reinforcement stitch after the buttonhole is sewn.

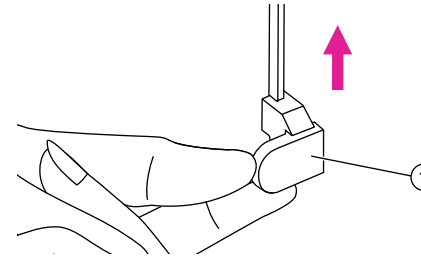

Raise the presser foot and cut the thread. To sew over the same buttonhole, raise the presser foot (it will return to its original position).

After sewing the buttonhole stitch, raise the buttonhole lever as far as it will go.

① Buttonhole lever

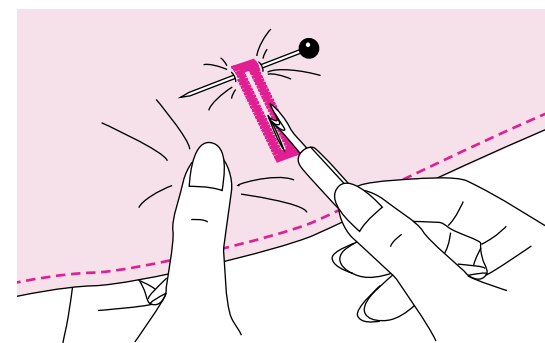

Use the seam ripper to cut the center of the buttonhole being careful not to cut any stitches on either side. Use a pin as a stopper at the bar tack so you do not cut too much.

Note

When cutting the buttonhole with the seam ripper, do not place your hands in the cutting direction, otherwise injuries may result.

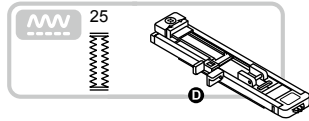

❖ Making a buttonhole on stretch fabrics

25: For jeans or stretch fabric with a coarse weave

When sewing buttonholes on stretch fabric, hook heavy thread or cord under the buttonhole foot.

Attach the buttonhole foot. Bring the gimp thread ends to the front of the foot and insert them into the grooves, then tie them there temporarily. Lower the presser foot and start sewing.

Set the stitch width to match the diameter of the gimp thread.

Once sewing is completed, pull the gimp thread gently to remove any slack. Cross the gimp in front of the needle and thread gimp ends into a large needle, pull to the wrong side and knot ends before cutting excess.

① Wrong side

Note

It is suggested that you sew with a stabiliser material under the fabric.

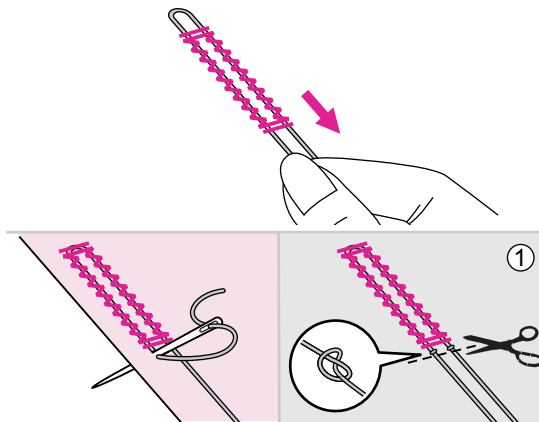
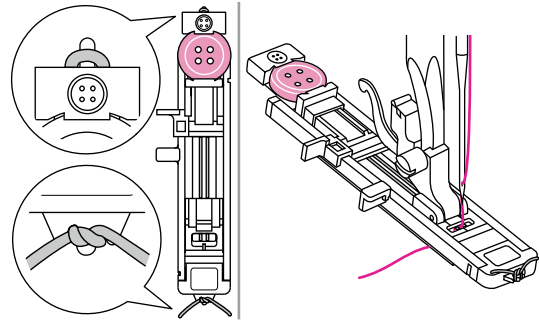

* Buttonholes are sewn from the front of the presser foot to the back, as shown.

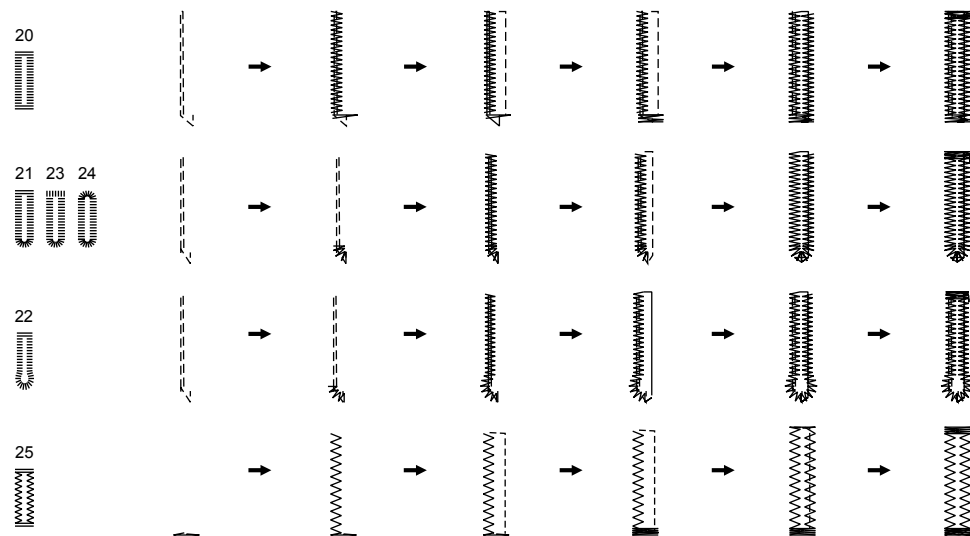

Eyelet stitch

Eyelet stitches are used for making belt holes and other similar applications.

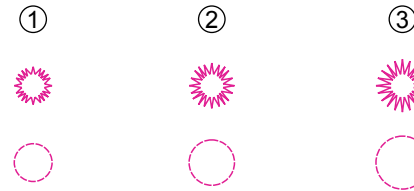
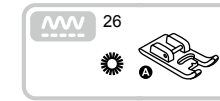

Using the satin stitch foot.

Press the "-" or "+" stitch width adjustment to button select the eyelet size.

- ① Small: 5.0mm
- ② Medium: 6.0mm
- ③ Large: 7.0mm

Lower the needle into the fabric at the beginning of the stitching, and then lower the presser foot lever.

Once sewing is completed, the machine automatically sews reinforcement stitches, then stops.

Make a hole at the center using an eyelet punch.

* Eyelet punch is not included with the machine.

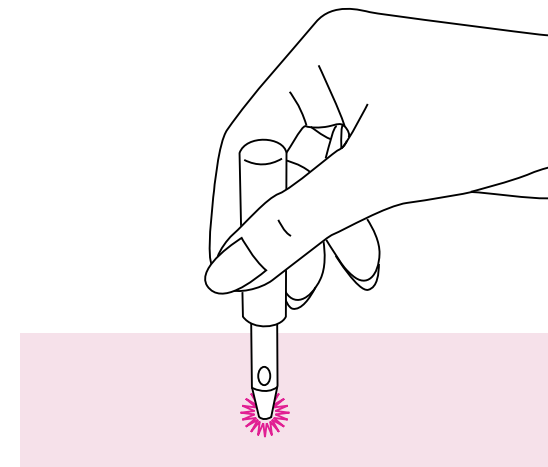

Note

When using the eyelet punch, place thick paper or some other protective sheet under the fabric before punching the hole in the fabric.

If thin thread is used, the stitching may be coarse. If this occurs, sew the eyelet twice one on top of the other.

Button sewing

Buttons can be sewn on with the sewing machine. Buttons with 2 or 4 holes can be attached.

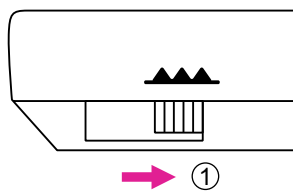
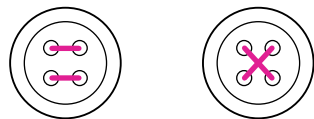
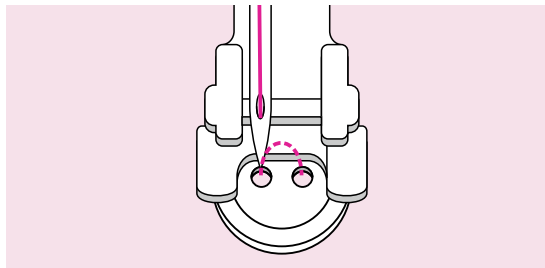
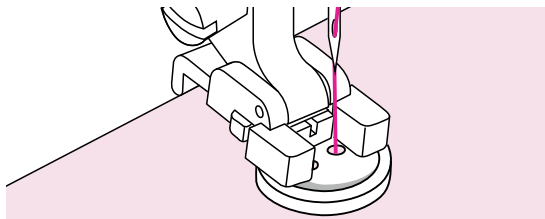
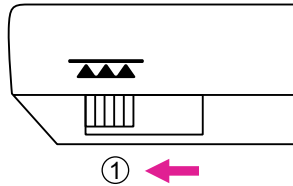
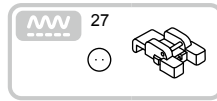

Using the button sewing foot.

Move the drop feed lever to lower the feed dogs.

① Lowered position

Put the work under the foot and place the button in desired position, then lower the foot.

Select the buttonhole sewing stitch and adjust the stitch width according to the distance between the two holes of the button.

Turn the handwheel to check that the needle goes cleanly into the left and right holes of the button.

For buttons with 4 holes, sew through the front two holes first, push work forward and then sew through the back two holes.

When you finish the work, move the drop feed lever to raise the feed dogs.

① Raised position

Zipper insertion

This foot can be set to sew on each side of the zipper, the edge of the foot guides the zipper to ensure straight placement.

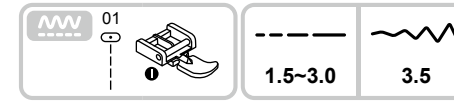

Using the zipper foot.

⚠ Attention

Zipper foot should be used for sewing straight stitches only. It is possible that the needle could hit the presser foot and break when sewing other patterns.

When sewing, be sure that the needle does not touch the zipper, otherwise the needle may bend or break.

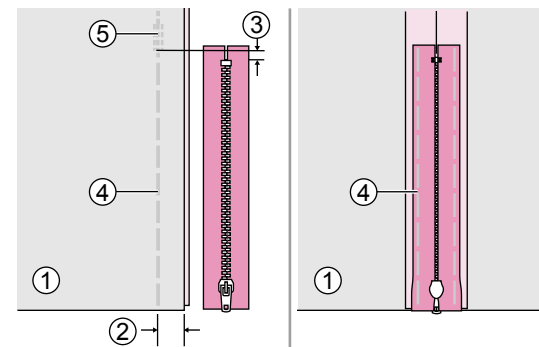

❖ Inserting a centered zipper

Place the right sides of the fabric together. Sew a bottom seam 2cm from the right edge of the zipper bottom stop position. Sew few reverse stitches for fixed. Increase the stitch length to maximum, set the tension below 2 and baste the remaining length of the fabric.

Press open the seam allowance. Place the zipper face down on the seam allowance with the teeth against the seam line. Baste the zipper tape in place.

- ① Wrong side
- ② 2cm
- ③ 5mm
- ④ Basting
- ⑤ Reverse stitches

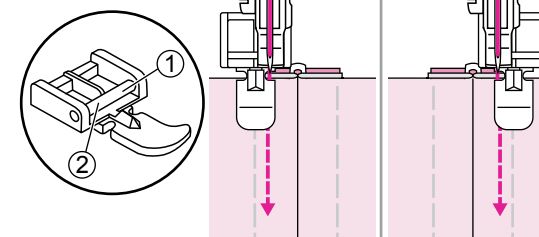

Attach the zipper foot.

- ① Attach the right pin for sewing the left side of the zipper.
- ② Attach the left pin for sewing the right side of the zipper.

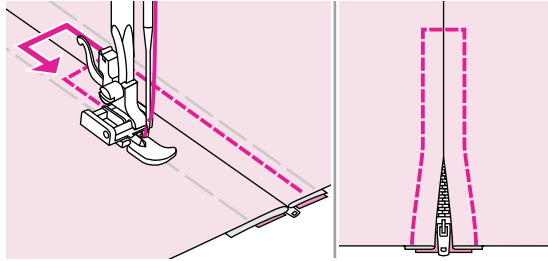

Stitching around the zipper. Remove the basting and press.

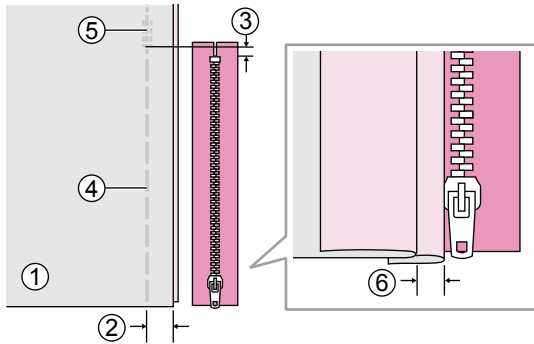

❖ Inserting a side zipper

Place the right sides of the fabric together. Sew a bottom seam 2cm from the right edge of the zipper bottom stop position. Sew few reverse stitches for fixed. Increase the stitch length to maximum, set the tension below 2 and baste the remaining length of the fabric.

Fold back to the left the seam allowance. Turn under the right the seam allowance to form a 3mm fold.

- ① Wrong side
- ② 2cm
- ③ 5mm
- ④ Basting
- ⑤ Reverse stitches
- ⑥ 3mm

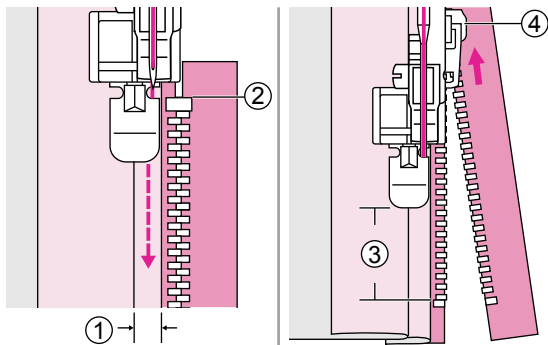

Attach the zipper foot. Attach the right pin for sewing the left side of the zipper. Sew the zipper to the piece of fabric with the extra 3mm, starting from the end of the zipper.

Stop the machine about 5cm from the top of the zipper. Lowered the needle into the fabric, raise the presser foot lever, and then open the zipper and continue sewing.

- ① 3mm
- ② The end of zipper
- ③ 5cm
- ④ Zipper

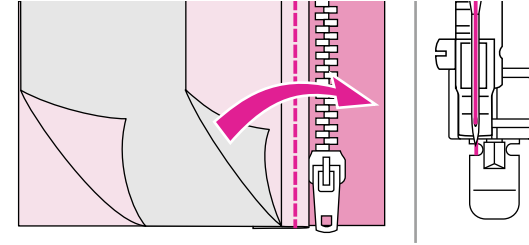

Turn the fabric right side out. Attach the left pin for sewing the rightside of the zipper.

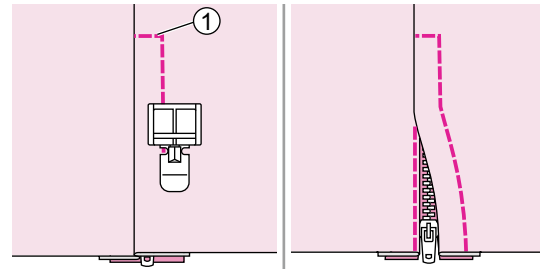

Stitch across the lower end and the right side of the zipper.

① Lower end

Stop the machine about 5cm from the top of the zipper. Remove the basting and open the zipper. Stitch the remaining of the seam.

Satin stitch sewing

Use the satin stitch foot for satin stitching and sewing decorative stitches.

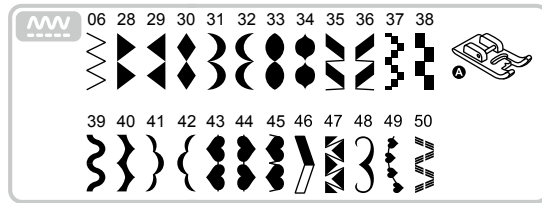

Using the satin stitch foot.

Note

When sewing very lightweight fabrics, it is recommended that you use interfacing or stabilizer on the wrong side of the fabric.

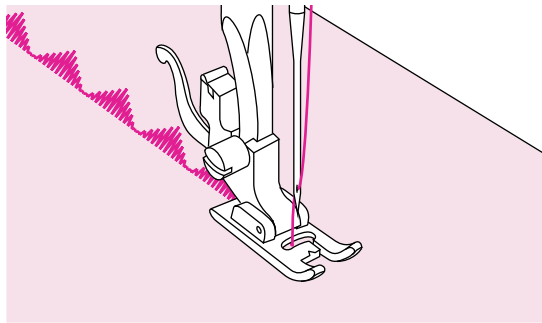

This foot has a groove on the underside which allows dense stitching to pass freely underneath.

To sew the satin or decorative stitch pattern, you may adjust the length and width of the pattern by pressing the stitch length and width adjustment button. Experiment with fabric scraps until you get the desired length and width.

Gathering

Ideal for clothing as well as home decor. It works best on thin to medium weight fabrics.

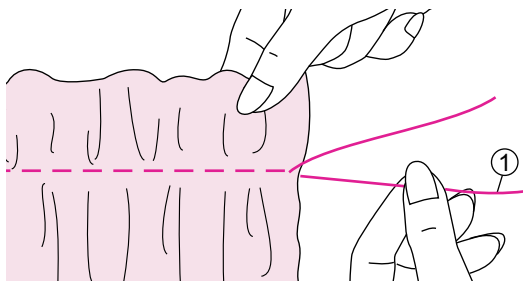

Using the all purpose foot.

Before sewing, please check the upper and bobbin threads are already pulled out about 5cm to leave enough room for sewing. Please refer to "Bringing up the bobbin thread" chapter for more information.

Set the tension below 2. Sew a single row (or many rows) of straight stitches.

Pull the bobbin threads and distribute the gathers evenly. Secure the threads at the other end.

① Bobbin thread

Smocking

The decorative stitch created by stitching or embroidering over gathers is called "smocking". It is used to decorate the front of blouses or cuffs. The smocking stitch adds texture and elasticity to the fabric.

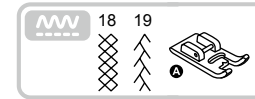

Using the satin stitch foot.

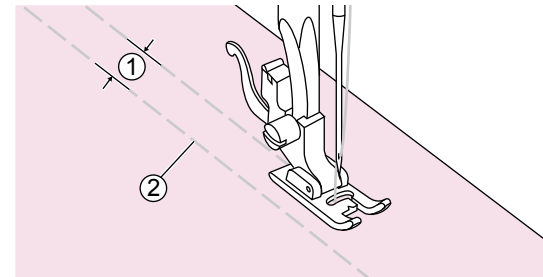

Increase the stitch length to maximum, set the tension below 2 and basting lines 1cm across the area to be smocked.

- ① 1cm
- ② Basting

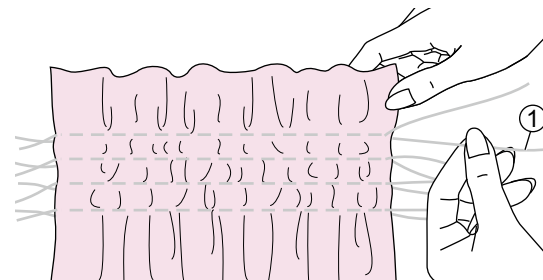

Knot the threads along one edge.

Pull the bobbin threads and distribute the gathers evenly. Secure the threads at the other end.

① Bobbin thread

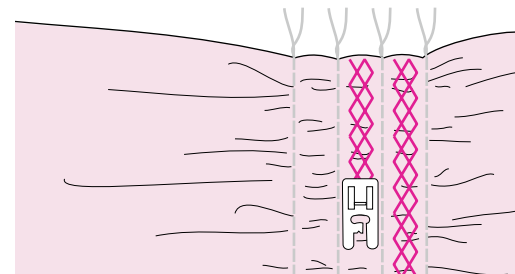

Reduce the tension if necessary and sew decorative pattern stitches between the straight seams.

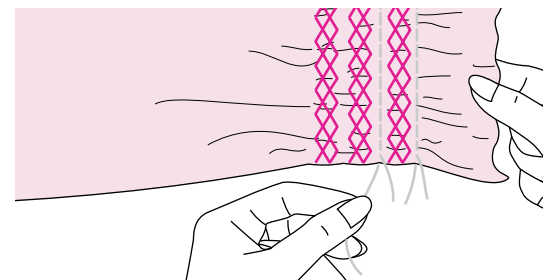

Pull out the basting.

Free motion darning, embroidery and monogramming

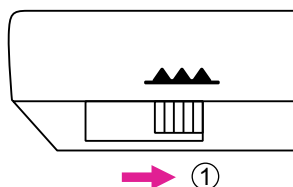
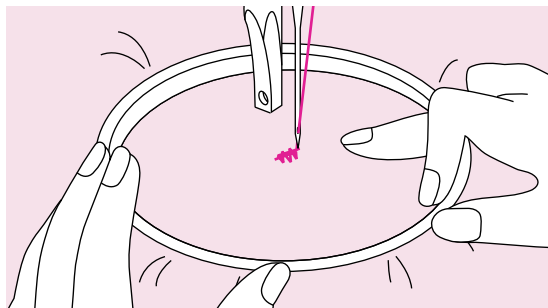
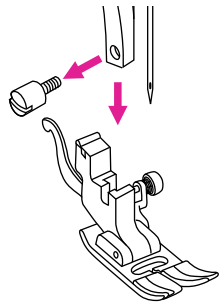
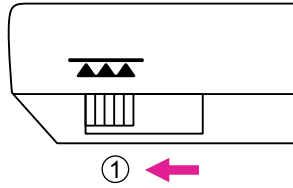
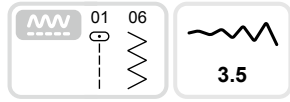

❖ Preparation for embroidering and monogramming

* Embroidery hoop is not included with the machine.

Move the drop feed lever to lower the feed dogs.

① Lowered position

Remove the presser foot and the presser foot holder.

Draw the desired lettering or design on the surface of the fabric.

Stretch the fabric between the embroidery hoop as firmly as possible.

Place the fabric under the needle. Make sure the presser foot bar is down to its lowest position.

Turn the handwheel towards you to bring up the bobbin thread through the fabric. Sew a few securing stitches at the starting point.

Hold the hoop with thumb and forefinger of both hands while pressing the material with the middle and third finger and supporting the outside of the hoop with your small finger.

⚠ Attention

Keep fingers away from moving parts, especially needles.

Note

When you finish the work, move the drop feed lever to raise the feed dogs.

① Raised position

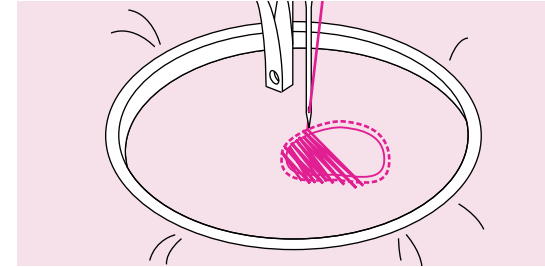

❖ Darning

First sew around the edges of the hole to secure the threads. Working from left to right, sew over the hole in a constant and continuous movement.

Turn the work by 1/4 and sew over the first stitching moving the work slower over the hole to separate the threads and not form big gaps between the threads.

Note

Free motion darning is accomplished without the sewing machine internal feed system. Movement of the fabric is controlled by the operator. It is necessary to coordinate sewing speed and movement of fabric.

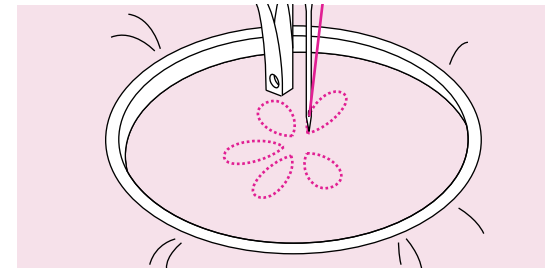

❖ Embroidery

Stitch along the outline of the design by moving the embroidery hoop. When sewing, make sure to maintain a constant speed.

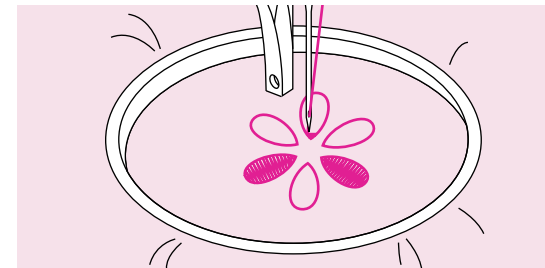

Fill in the design working from the outline towards the inside. Keep the stitches close together.

You will get longer stitches by moving the hoop faster and shorter stitches by moving the hoop slower.

Secure with reinforcement stitches at the end of the design.



❖ Monogramming

Sew at constant speed, moving the embroidery hoop slowly along the lettering.

When the letter is finished, secure with reinforcement stitches at the end of the design.

Quilting

Sandwich batting between the top and bottom layers of fabric is call "Quilting". The top layer is usually formed by multiple geometrically shaped pieces of materials joined together.

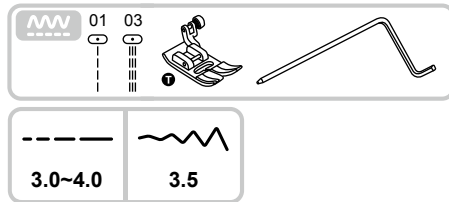

Using the all purpose foot with edge/quilting guide.

❖ Using the edge/quilting guide

Attach the edge/quilting guide in the presser foot holder as illustrated and set the space as you desire.

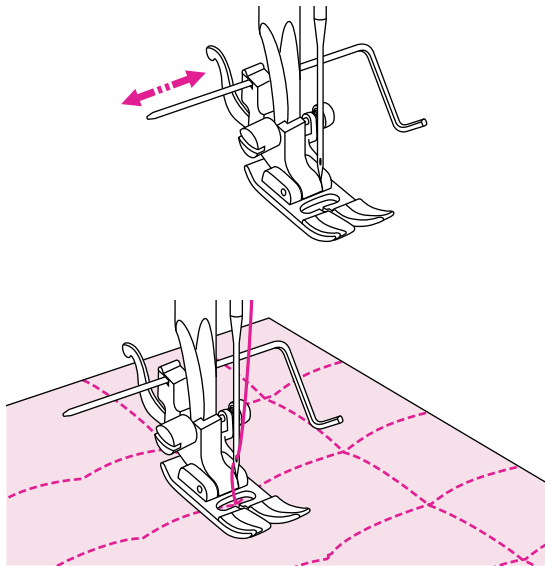

Sew the first row and move over the fabric to sew successive rows with the guide riding along the previous row of stitching.



Using the all purpose foot.

❖ Joining the pieces of the fabric

Place the two pieces of fabric with the right side together and sew with the straight stitch.

Join the pieces of fabric with a seam allowance of 5mm.

Sew with the side of the presser foot aligned with the edge of the fabric.

- ① Wrong side
- ② 5mm

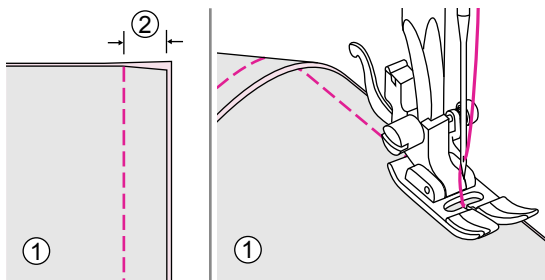

Using the all purpose foot or satin stitch foot..

❖ Patchwork stitching

Place the two fabrics, right sides together and sew using a straight stitch.

Open the seam allowance and press it flat.

- ① Wrong side

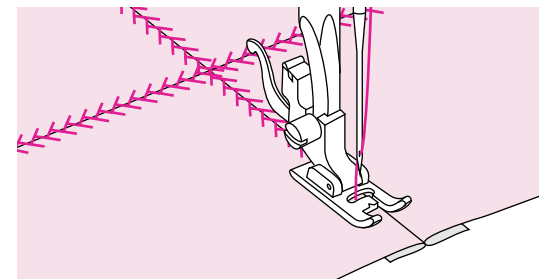
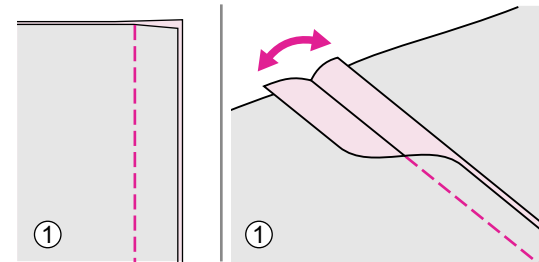

Working on the right side of the fabric, place the center of the presser foot on the seam line of the joined fabrics and stitch over the seam.

Applique

You can create and applique by cutting a different piece of fabric into a shape and using it as a decoration.

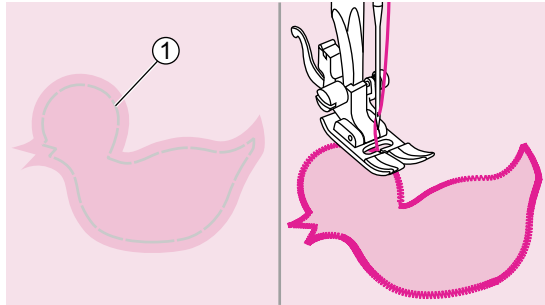

Using the all purpose foot.

Cut out the applique design and baste it on the fabric. Sew slowly around the edge of the design.

① Basting

Trim the excess material outside the stitching. Make sure not to cut any stitches. Remove the basting.

Fagoting

Stitching across an open seam is called "fagoting". It is used on blouses and children's clothing. This stitch is more decorative when thicker thread is used.

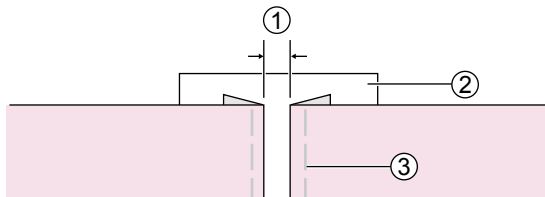
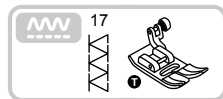

Using the all purpose foot.

Separate the folded edges of the fabric pieces with a gap of 4mm and baste them onto a piece of thin paper or water-soluble stabilizer sheet.

- ① 4mm
- ② Thin paper or water-soluble stabilizer
- ③ Basting

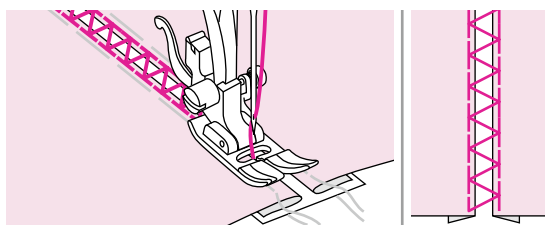

Align the center of the presser foot with the center of the two pieces of fabric and begin sewing.

After sewing, remove the stabilizer and basting.

Scallop stitch

The wave-shaped repeating pattern, that looks like shells, is called "scalloping". It is used to decorate the collar of blouses and the edges of knitting projects.

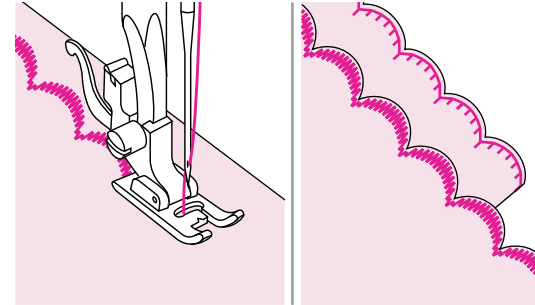
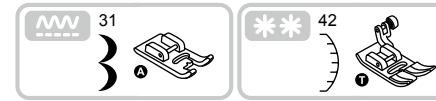

Using the satin stitch foot or all purpose foot.

❖ **Scallop edging**

Stitch along the edge of the fabric, making sure not to sew directly on the edge of the fabric.

For better results, apply spray starch onto the fabric and press with a hot iron before it is sewn.

Trim the fabric close to the stitching taking care not to cut the stitches.

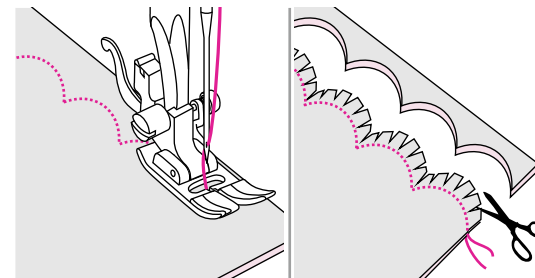
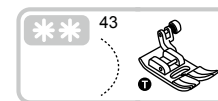

Using the all purpose foot.

❖ **Scallop hem**

Fold the fabric right side together. Sew along the folded edge as illustrated.

Cut the fabric along the seam leaving an allowance of 3mm for seaming.

Notch the allowance.

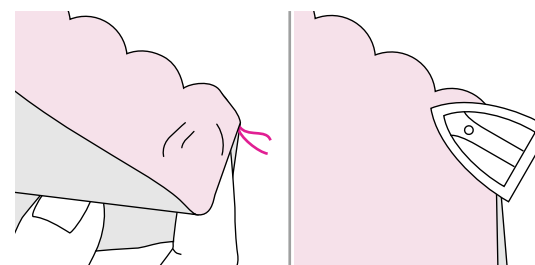

Turn the fabric over and push out the curved seam to the surface and iron it.

Embroidery quick guide

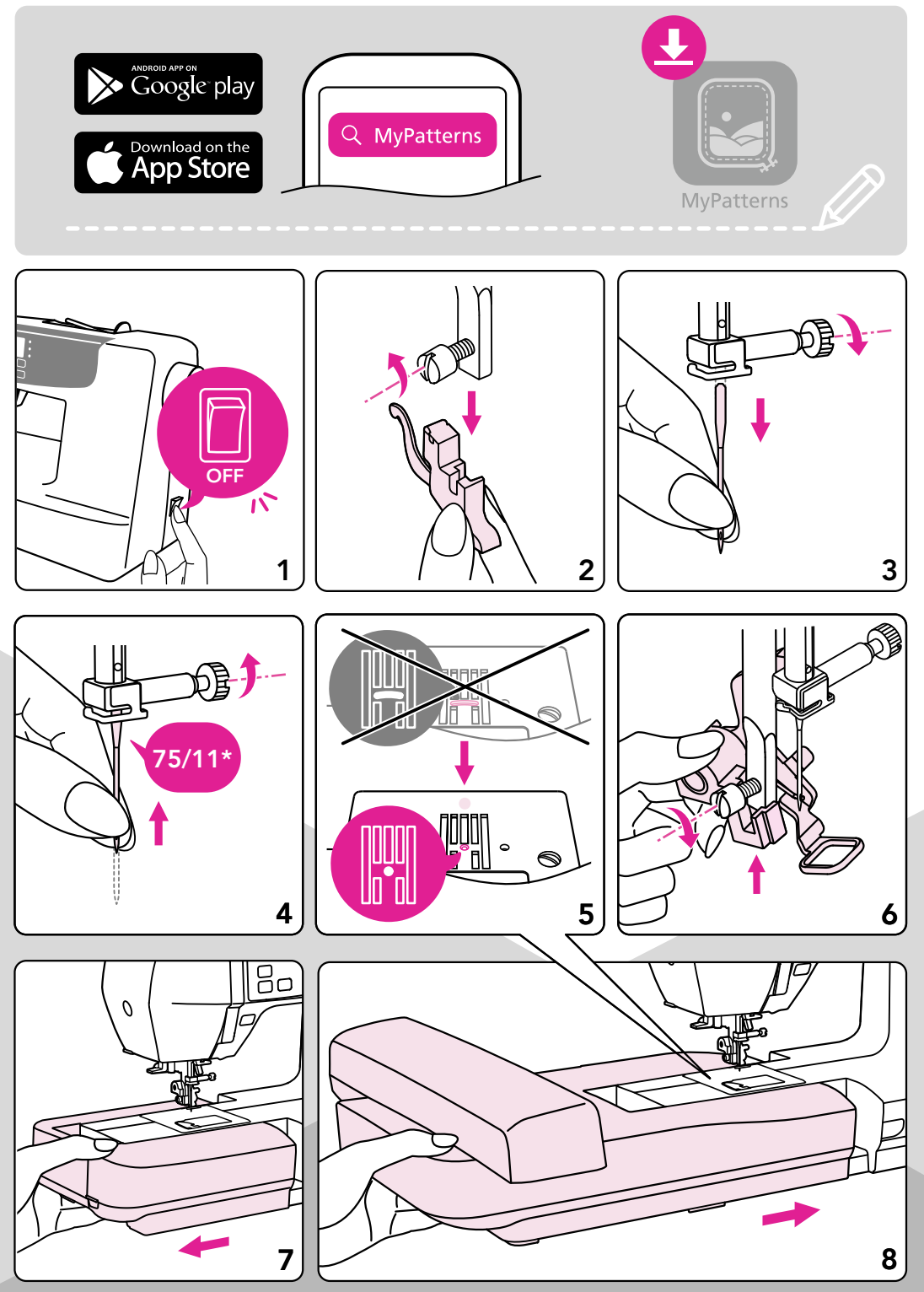

Embroidery Preparation

* Please refer to page "Matching needle/fabric/thread" and "Replacing the needle" for more information.

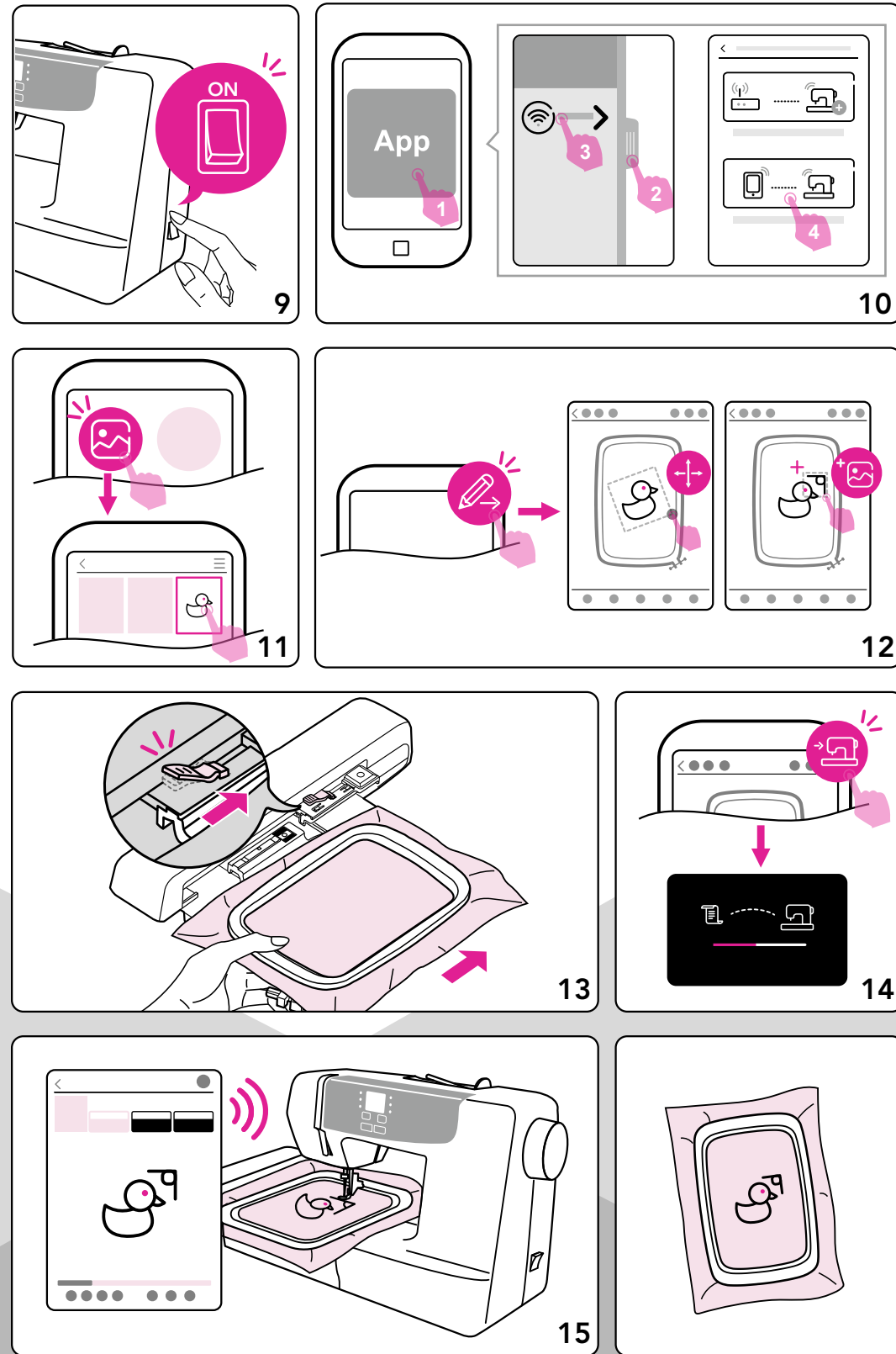

Important embroidery information

❖ Embroidery threads

A good quality thread is essential for embroidery to avoid poor stitch formation, needle break, etc.

Good embroidery performance will be effective by using 40wt glossy rayon or polyester embroidery threads as upper threads. They are available in a wide range of colors for beautiful embroidery.

Polyester threads

Polyester is a glossy thread with high tensile strength, hard wearing and colorfast features, which is suitable for all type of embroidery.

Rayon threads

Rayon is a soft viscose fiber with a brilliant sheen and suitable for fine, delicate embroidery, or items that will not receive excessive wear and tear.

Metallic threads

Metallic thread is a light to medium weight thread suitable for special effects in embroidery.

Reduce the thread tension when embroidering with metallic threads.

Embroidery needle

- Select correct thread size and needle size for embroidery.
- Replace the needle regularly.

Note

Please use the second spool pin when metallic or special material threads been used.

❖ Bobbin threads

Bobbin Fill (special bobbin thread)

Bobbin Fill is an especially soft and light polyester thread suitable for bobbin thread. This special bobbin thread ensures a steady thread tension and best performance of pieces of the upper and bobbin thread.

❖ Darning and embroidery thread

Fine mercerized cotton thread which is suitable for embroidering on cotton.

Note

In most cases, bobbin thread for embroidery is either white or black. Some special cases require the same for upper and bobbin thread.

❖ Stabilizer

Tear-away stabilizers

- The excess is easily to tear away.
- One or more layers can be used.
- Available for light and thick materials.
- Before hooping, apply a little spray onto back side of fabric can bring more stability on performance.
- Carefully tear away excess stabilizer from the back of the project after completion.
- Ensure the embroidery pattern will not be deformed.
- Leaving the stabilizer under the larger embroidered areas.

Application:

- Available for all woven materials and non-stretch materials.

Cut-away stabilizers

- One or more layers can be used.
- Available for light and thick materials.
- Before hooping, apply a little spray onto back side of fabric can bring more stability on performance.
- Carefully cut away excess stabilizer from the back of the project after completion.
- Ensure the embroidery patten will not be deformed.
- Leaving the stabilizer under the larger embroidered areas.

Application:

- For all elastic materials.

❖ Adhesive Spray

Avoid using spray adhesive next to your embroidery machine.

- Keep about 25-30 cm distance while using the spray.
- Use the spray carefully.
- Spray the stabilizer and adhere to back side of material carefully and iron to prevent wrinkles.

Application:

- Keep stretch and knitted material in shape.
- Prevent layers of fabric slipping while smooth material been used.
- Appliques can be exactly positioned.
- Place cloth on stabilizer, e.g. pocket flaps.
- Do not place the napped materials(i.e. velvet) in the hoop. It may have hoop marks on the material.
- Fix the area to be embroidered.

Spray starch for additional stiffening

Spray starch is ideal for additional stiffening on fine, soft or loosely woven materials.

- Spray on the area to be embroidered
- Wait until dry; or press gently with a warm iron if necessary
- Always use an additional stabilizer such as water soluble stabilizer to be applied on the material.

Application:

- Ideal for fine, loosely woven materials, e.g. batiste, fine linen, etc.

❖ Iron-on interfacing

Iron-on interfacings are available in a variety of weights. Iron-on interfacings should be selected to suit the material being used. Use an iron-on interfacing which is easily removable from the material.

Fuse the iron-on interfacing to the wrong side of material and press.

Application:

- Please use an appropriate stabilizer and cut it in a bigger shape than your embroidery pattern. Then place it onto the design for support.

Paper-backed adhesive stabilizer

- Place stabilizer in hoop with paper side up.
- Use a pointed tool (e.g. scissors) to score the paper.
- Remove the paper to reveal the sticky surface.
- Position the fabric over the sticky surface and smooth into place.

Application:

- Intended for delicate materials such as jersey or silk etc.
- For hard-to-hoop parts and materials.

Note

Make sure that the adhesive residue on needle, stitch plate and hook area are totally removed.

Water soluble stabilizer

Water soluble stabilizer looks like plastic wrap. When you finish embroidery design, simply submerge project in warm water to dissolve stabilizer. Water soluble stabilizer helps keep the stitches from disappearing in high-pile fabrics (such as towels or fluffy cotton).

- Place the water-soluble stabilizer on top of the fabric.
- Place all layers together into the embroidery hoop.
- Use adhesive spray to fix stabilizer if necessary.
- For pile fabrics, an additional stabilizer on the wrong side is suggested for reinforcement.
- After finishing the sewing, dissolve it and lay the project until dry.

Application:

- Available for towel, velvet, bouclé and etc.
- Available for fine, sheer material such as organdy, bastiste and etc.
- Available for lace embroidery.

Embroidery unit overview

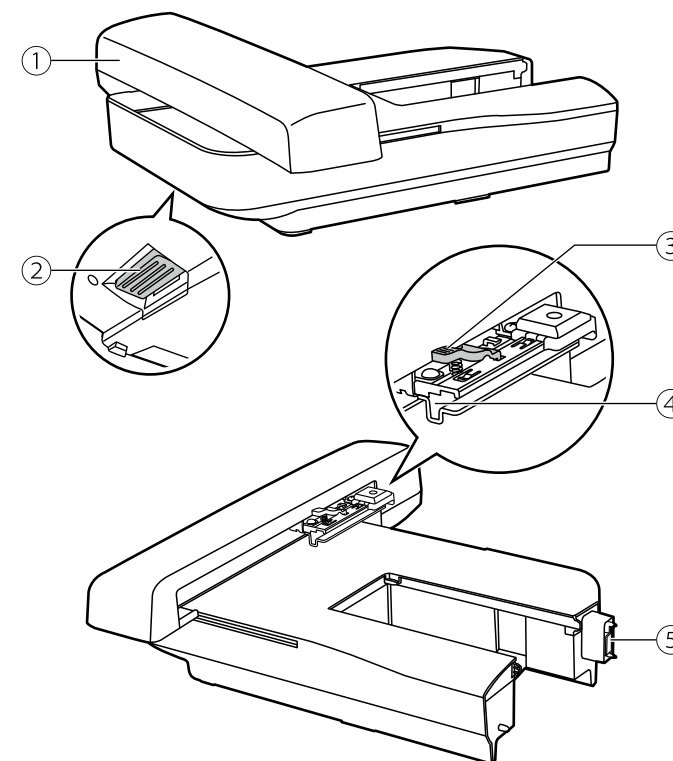

- ① Embroidery carriage
- ② Embroidery unit release button
- ③ Hoop-securing lever
- ④ Embroidery hoop holder
- ⑤ Embroidery unit detection device

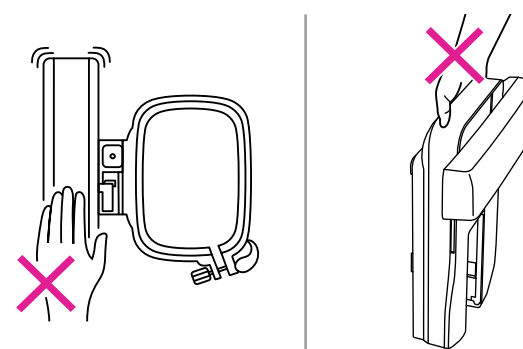

Note

Do not touch the embroidery unit detection device. The connector could be damaged, and it may cause malfunctions.

Do not press or force on embroidery carriage, and do not lift it up. It may cause malfunctions.

Do not carry the embroidery unit by holding the release button compartment.

Embroidery hoop overview

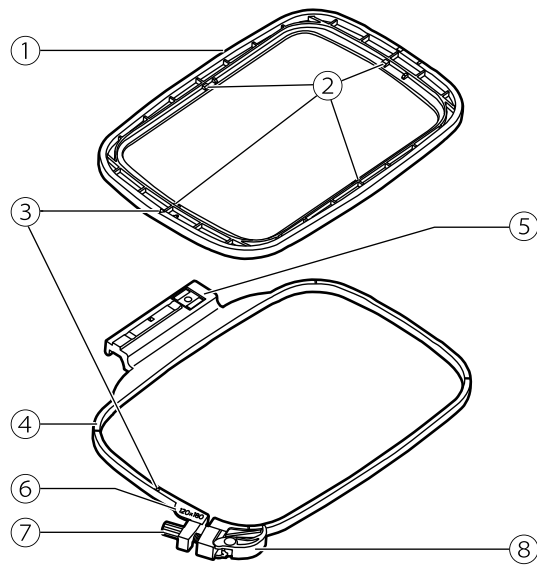

- ① Inner hoop
- ② Center marks
- ③ Triangular mark
- ④ Outer hoop
- ⑤ Embroidery hoop connector
- ⑥ Hoop size marks
- ⑦ Fastening screw
- ⑧ Quick release device

Preparing the embroidery hoop

❖ Attaching a stabilizer to the fabric

⚠ Attention
 Always use stabilizer material when embroidery. The needle may break or bend without using stabilizer material for thin fabrics or stretch fabrics in embroidering works. Furthermore, the pattern may not be sewn perfectly.

To obtain the best embroidery performance, it is important to use stabilizers.

Prepare stabilizer material that is larger than the embroidery hoop being used.

- ① Wrong side
- ② Size of embroidery hoop
- ③ Stabilizer

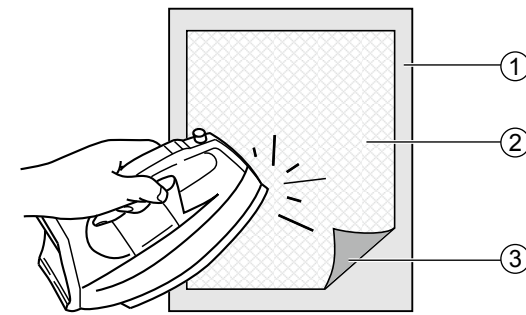
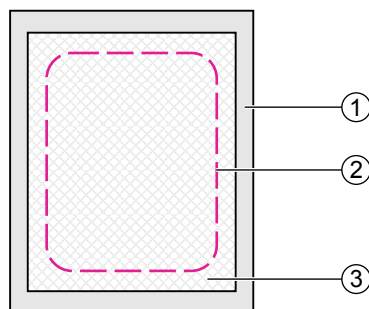

If you are using adhesive stabilizers, place the adhesive surface of the stabilizer material against the wrong side of the fabric, and iron.

- ① Wrong side
- ② Stabilizer
- ③ Adhesive surface

❖ Hooping the fabric

⚠ Attention
 Thick layers of fabric and stabilizer may cause skipped stitches, or broken threads, needles and damage on embroidery hoops.

Loosen the fastening screw under the outer hoop.

Separate the inner hoop and outer hoop.

- ① Fastening screw

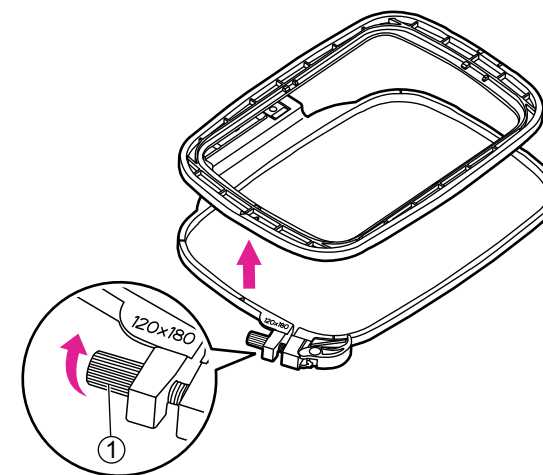

Place the outer hoop on a sturdy flat space.

Make sure the fabric with right side upwards, place the stabilizer underneath the fabric for better support, and then place the fabric and stabilizer altogether on the outer hoop. It can achieve better embroidery performance.

Align both triangular marks and fix the fabric in place.

- ① Inner hoop's triangular mark
- ② Outer hoop's triangular mark

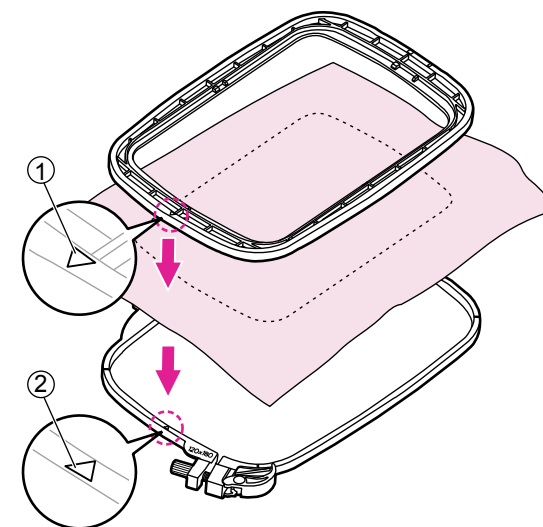

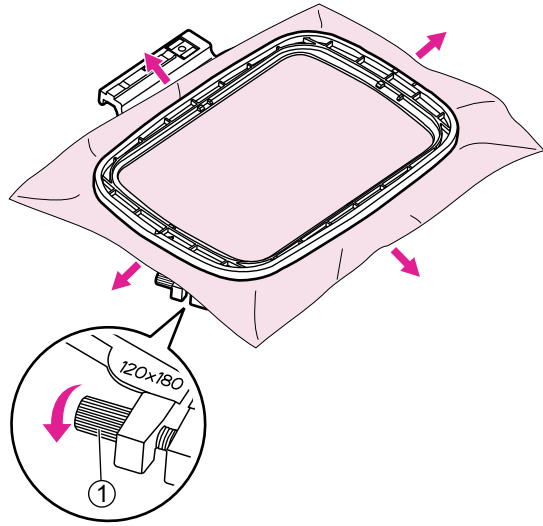

Place the inner hoop on the fabric and press firmly until they are securely fit to outer hoop perfectly. If the inner hoop cannot fit properly, loosen the outer hoop's fastening screw and adjust until fitted.

When the fabric and inner hoop are completely fit into the outer hoop, pull the fabric from the four sides marked with the arrows so that the fabric is stretched drum-tight in the hoop, and then press the inner hoop downwards so that it sinks into the outer hoop a little and tighten the fastening screw.

- ① Fastening screw

❖ Use the quick release device

If same type of fabric is used for embroidery, open the quick release device under the outer hoop.

Separate the inner hoop and outer hoop.

- ① Quick release device

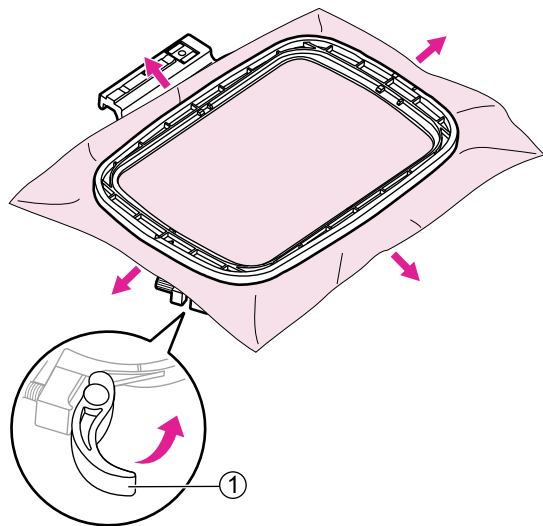
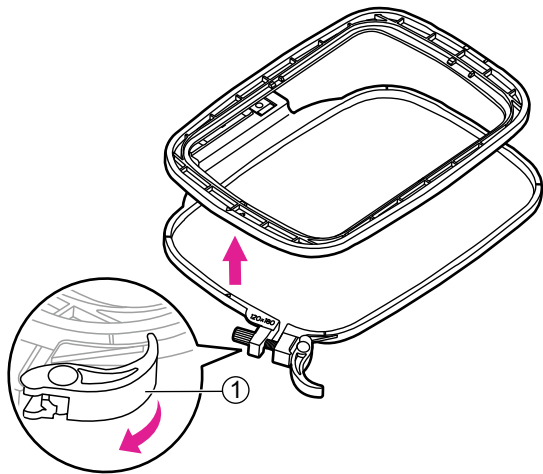

Place the inner hoop on the fabric and press firmly until they are securely fit to outer hoop perfectly, pull the fabric from the four sides marked with the arrows so that the fabric is stretched drum-tight in the hoop, and then press the inner hoop downwards so that it sinks into the outer hoop a little and close the quick release device.

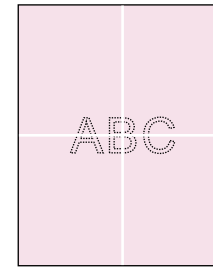

❖ Using embroidery sheet

Make a mark with a chalk at the center of the position for the pattern to be embroidered.

Loosen the fastening screw or open the quick release device (if same type of fabric is used for embroidery).

Separate the inner hoop and outer hoop.

- ① Fastening screw
- ② Quick release device

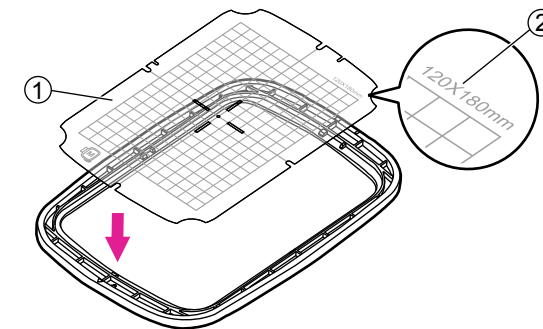
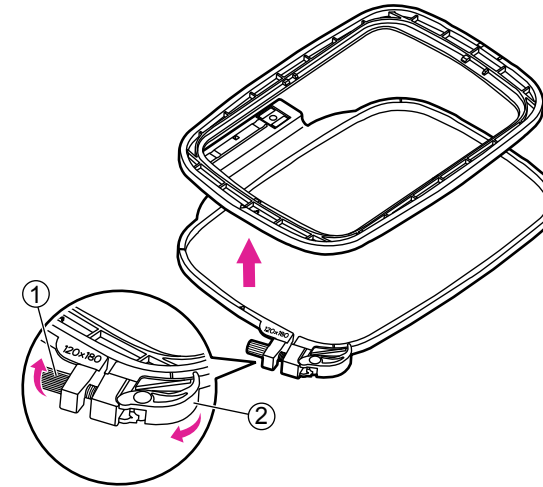

Place the embroidery sheet on the inner hoop. Make sure the hoop size printing is on top right side.

- ① Embroidery sheet
- ② Hoop size

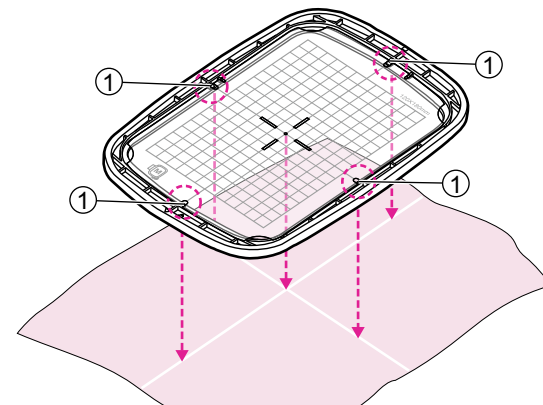

Line the mark on the fabric up with the base line on the embroidery sheet.

Also, align the cross mark of the fabric to the center marks on the four sides of the inner hoop.

- ① Center marks

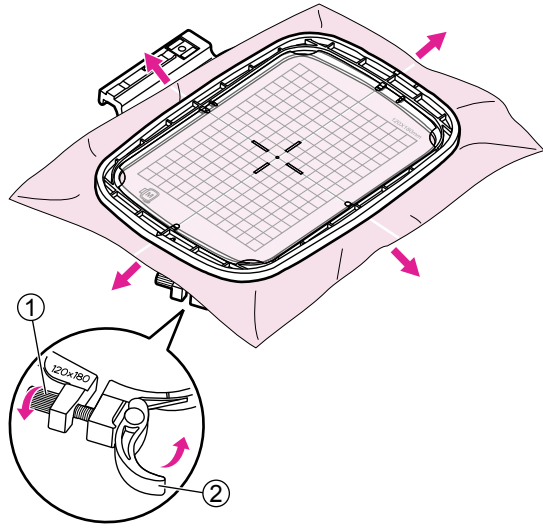

Place the inner hoop on the fabric and press firmly until they are securely fit to outer hoop perfectly. If the inner hoop cannot fit properly, loosen the outer hoop's fastening screw and adjust until fitted.

When the fabric and inner hoop are completely fit into the outer hoop, pull the fabric from the four sides marked with the arrows so that the fabric is stretched drum-tight in the hoop, and then press the inner hoop downwards so that it sinks into the outer hoop a little and tighten the fastening screw or close the quick release device (if same type of fabric is used for embroidery).

- ① Fastening screw
- ② Quick release device

Remove the embroidery sheet.

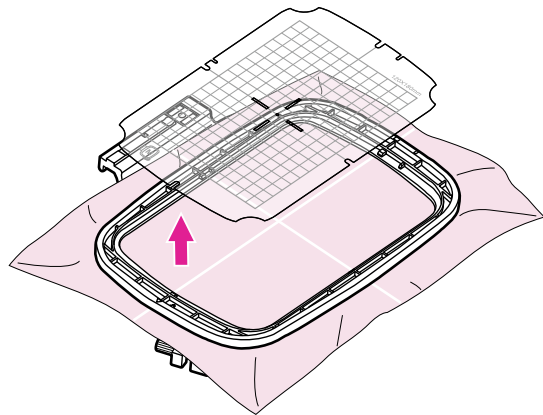

Embroidery Process

Step 1. Preparation for embroidery



Turn the power switch to off ("O"). Raise the presser foot lifter.

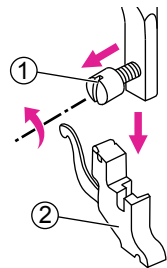

Loosen the screw counter-clockwise to remove the presser foot holder.

- ① Screw
- ② Presser foot holder

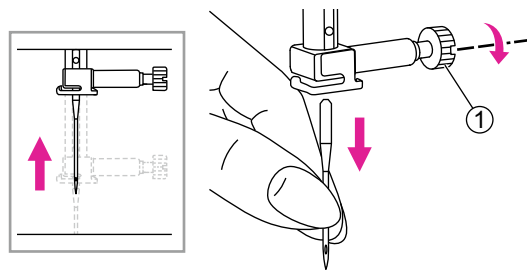

Turn the handwheel toward you to raise the needle then loosen the needle clamp screw to remove the needle.

- ① Needle clamp screw

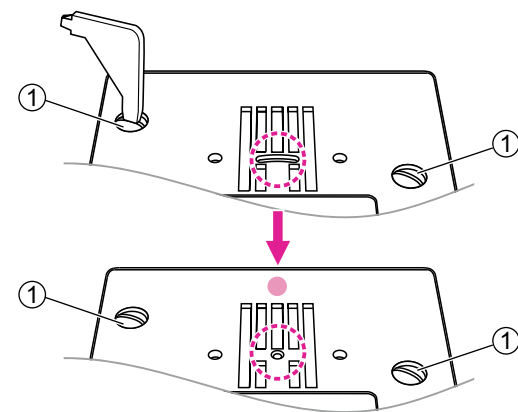

Remove the screws on the needle plate then remove the needle plate.

Change the straight stitch plate and tighten the screws.

- ① Screws

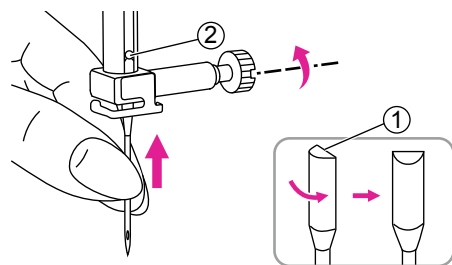

Inserting a 75/11 needle, keep the flat side of the shaft to the back.

Please refer to page "Matching needle/fabric/thread" and "Replacing the needle" for more information.

- ① Flat side of the shaft
- ② Pin

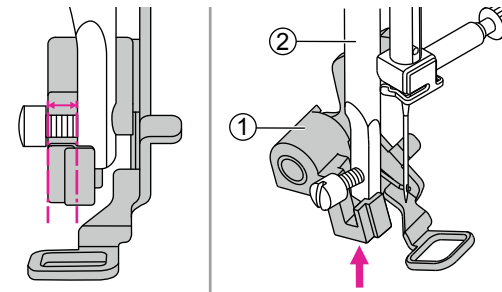

Make the embroidery foot lever upwards.

Tilt the embroidery foot and insert it from left to right so that the notch fits into the presser foot bar, and then push the embroidery foot upwards until it is aligned with the screw.

- ① Embroidery foot
- ② Presser foot bar

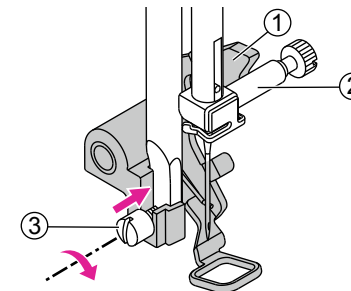

The embroidery foot lever will be against the top of the Needle clamp screw, then tighten the screw by using the screwdriver.

- ① Embroidery foot lever
- ② Needle clamp screw
- ③ Screw



Note

Please check and make sure the presser foot is raised and remove embroidery hoop first before attaching embroidery unit onto the machine.

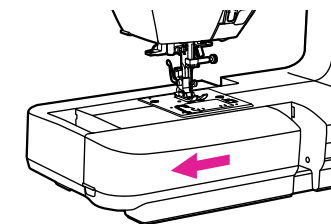

Hold the sewing table horizontally, then pull toward the left to remove it from the machine.

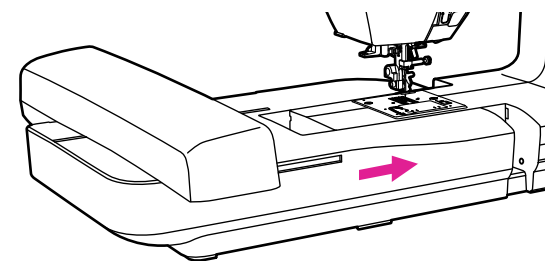

Slide the embroidery unit onto the machine arm. Push lightly until the unit clicks into place.

Attention

Once embroidery unit is installed, foot control cannot be operated.

Step 2. Starting the connection



MyPatterns

❖ Embroidery software installation

Search "MyPatterns" on Google Play/Apple Store to download and install the application in order to perform the following setting steps.

To reach the best user experience, we recommend you to use the tablet to connect with the machine for further operation.

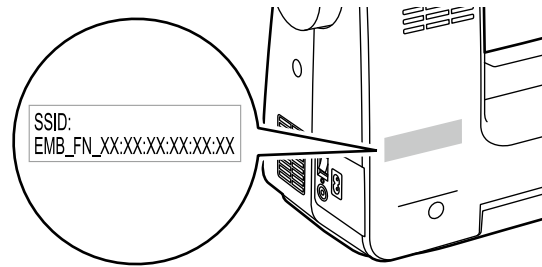

Note
The SSID sticker is on the back of the machine. The SSID starts with EMB_FN_XX:XX:XX:XX:XX:XX. Each machine has its own SSID and please take note of it before starting the connection, especially in a public environment.

Step 2-A. Connection mode: Router

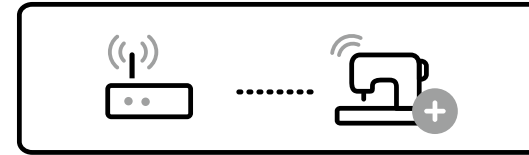

❖ The first time to set up

Before setting up, please confirm that the environment is equipped with the WiFi router and make sure it is connected to the internet in order to starting the connection.

Please set the SSID of your WiFi access station in English letters or digital numbers then re-connect again.

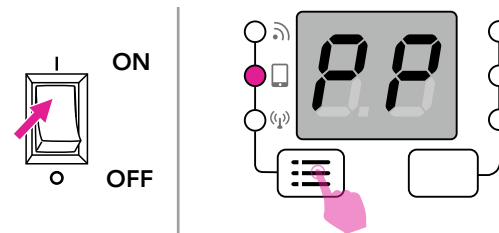

Turn on the power, and check if the screen shows "PP" and the second light is on. If it is not, please long press the connection mode switch button to switch the light.

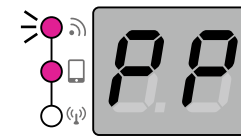

The WiFi light will start flashing, which means ready to connect machine.

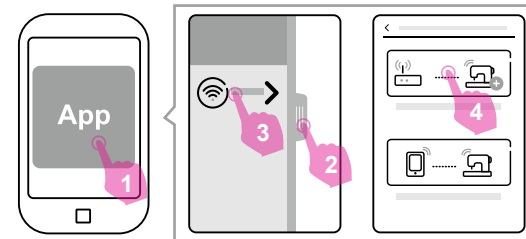

Please open the app on your portable device. (smart phone or tablet)

Please slide or press the bar at the left side, and press "Add a new connection". Then choose "Set up the Router Mode connection."

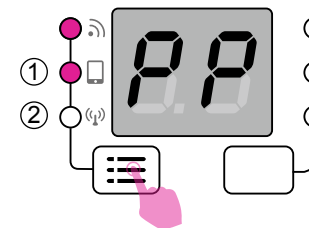

Note
In embroidery mode, long pressing the group switch button can change the connection mode according to your demand.
The connection mode is including:
① Point-to-point mode(PP)
② Router mode(AP)
Note: the connection mode switch button could not apply until AP mode was set up.

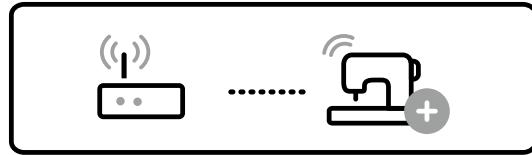

❖ Connection

When router mode setting was done, the machine will connect with the router automatically next time.



When the screen shows AP and the WiFi light start flashing, the machine is ready to connect with the App.



Start the App and the connection will follow automatically. When the connecting is done, the screen shows "GO" and the connection with the App is successful.

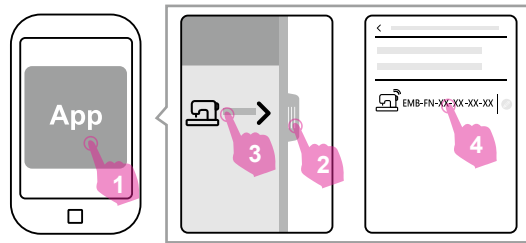

Note
If the connecting does not follow automatically, please slide or press the bar at the left side, and press "Machine in the router network." The connected machines with the router will be indicated and press one to enable the connection.

Step 2-B. Connection mode: Point-to-point

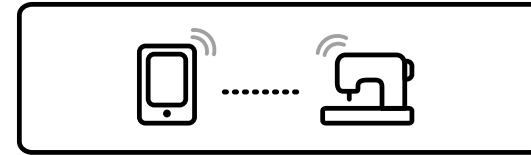

⚠ Attention

In this connection mode, the internet function of the portable device itself cannot be used and the cloud download function cannot be used as well.

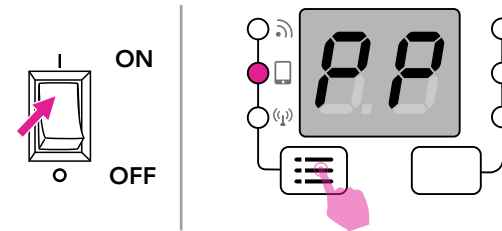

Turn on the power, and check if the screen shows "PP" and the second light is on. If it is not, please long press the connection mode switch button to switch the light.



The WiFi light will start flashing, which means ready to connect machine.

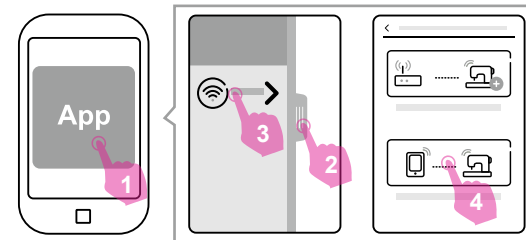

Please open the app on your portable device. (smart phone or tablet)

Please slide or press the bar at the left side, and press "Add a new connection". Then choose "Set up the point-to-point Mode connection."



Once it has successfully connected to the APP, the screen will show GO, which means that the embroidery function can now be normally executed.

Note

Point-to-point mode is recommended for performing embroidery when there is a lot of wireless signal interference environment, this will reduce the interference among different devices.

Step 3. Import/edit embroidery pattern

Start exerting your creativity through the app and edit exclusive embroidery creations.

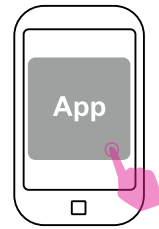

The app provides users with the best embroidery experience; you can freely and easily import and create your favourite images through the portable device. Once editing is completed, it can be transmitted to the embroidery machine through WiFi to perform embroidering and monitor the embroidering through the screen.

Embroidery format packages supported for app importing includes: .zhs, .pes, .dst, .jef, .xxx, .hus, .exp, .pec, .pcs, .sew, .vip and .vp3.

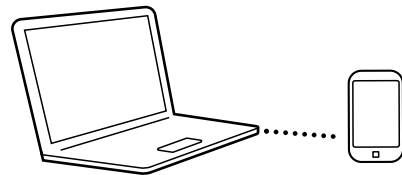

❖ Importing files on iOS

After connecting to an iOS device through iTunes, simply select the app and press add file to add the file.

❖ Importing files on Andriod

After physically connecting to a mobile phone, use the file manager software and locate the StitchPro/MyDesign folder on the internal storage, and place the files there.

❖ Location of imported files on App

Open the app and locate the MY DESIGN folder to open the loaded image files.

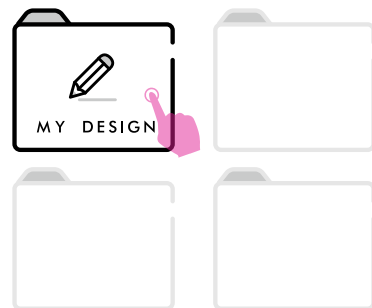

Step 4. Install the embroidery hoop

After editing the embroidery image file, place the embroidery hoop with the corresponding size to perform the preparations for embroidering.

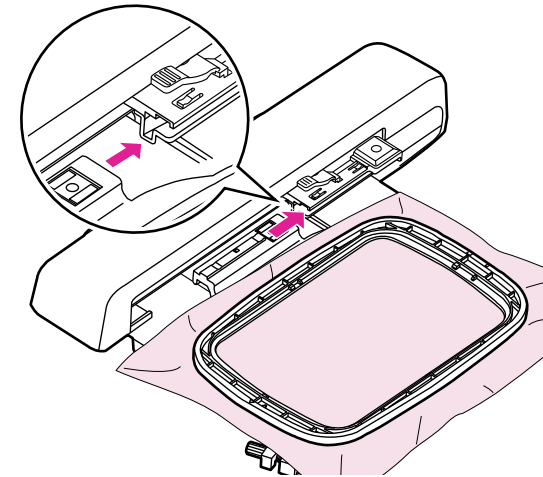

The embroidery hoop has two built-in sizes which are 120x80mm and 50x70mm, respectively. Select the corresponding size according to the image design.

Once the power is turned on, hoop the fabric in the selected embroidery hoop and use your finger to lightly raise the presser foot, slide the embroidery hoop into the embroidery unit to assemble them. When you hear a "click", it means that the embroidery hoop installation is completed.

Note

Please raise the presser foot while the embroidery hoop is resetting.

The reset action must be performed every time when a different size embroidery hoop is re-installed.

⚠ Attention

Please check the fabric thickness in advance, if the fabric is too thick, please don't use it for embroidery.

If there is space between the presser foot and the fabric, the fabric can be embroidered. If there is not space, do not embroider the fabric. Otherwise, the needle may break, resulting in injury.

Please be careful when sewing overlapping patterns as the needle might break due to the difficulty of fabric penetration.

Step 5. Begin to embroider

Once preparation is completed, the embroidery file can be transmitted to the embroidery machine through the APP to start embroidering.

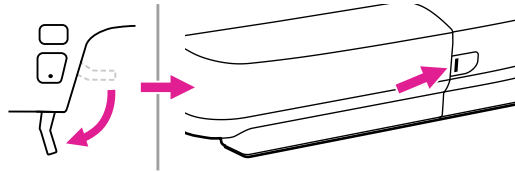

After the embroidery app has successfully transmitted the embroidery file to the embroidery machine, lower the presser foot and the status light will change from yellow to green, which means that everything is ready. Please place the first color of threads to embroider according to the instruction on the app screen.

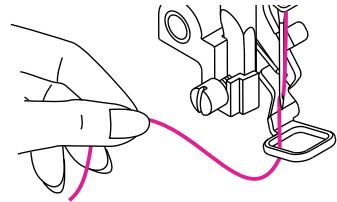

Note
Please refer to page "Threading the upper thread" chapter for more information.



Long press start/stop button to start embroidering.

Once all the color threads have been embroidered, your exclusive embroidery design has completed.

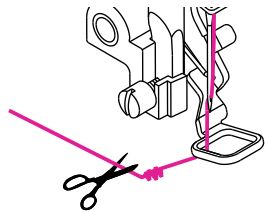

Note
After sewing 5 to 6 stitches, press the start/stop button again to stop the embroidering. Raise the presser foot. Cut the thread at the beginning of the stitching. Lower the presser foot. Press the start/stop button to continue embroidering.

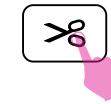

Note
When the thread needs to be changed, press start/stop button to stop embroidering, and press the thread cutter button to cut the thread.

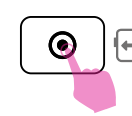

Different colored threads will need to be changed several times according to the embroidery design, please place the corresponding colored threads in sequence.
When users pause the machine to change threads and the embroidery unit is too close to needle, please press the auto lock button. The embroidery hoop will be moved to center position for you to change thread easily.
After the thread change is complete, long press the start button and the embroidery hoop will automatically return to the paused position. The machine will continue embroidering.

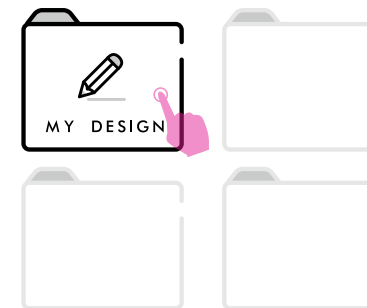

❖ Load a Design after interruption

When you need to leave temporarily during embroidering, save current embroidery pattern first. The current numbers of stitches will be recorded in app. Then turn the embroidery machine power off and remove the embroidery unit apart.

When you re-start previous embroidery, connect the machine and open the app. Find the saved embroidery pattern in MY DESIGN folder and load it. After loading the file completely, you can continue to embroider from the previous point again.

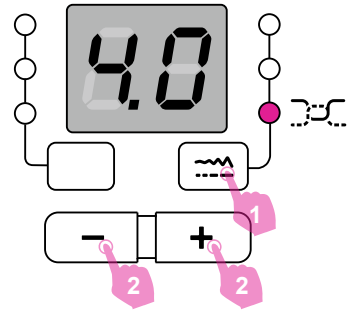

❖ Adjust the thread tension

- Proper setting of tension is important for good sewing. There is no single tension setting appropriate for all the stitch functions and fabrics.
- Basic thread tension setting: "4"
- Press the stitch adjustment button, when the tension light is on, the embroidery thread tension can be adjusted.

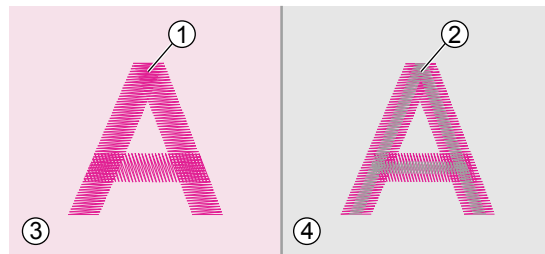

The thread tension is correct when upper thread is just visible on back of the fabric.

- ① Upper thread
- ② Bobbin thread
- ③ Right side
- ④ Wrong side

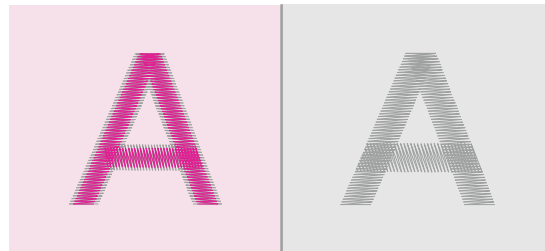

When the bobbin thread is visible on the front of the fabric, the thread tension is too tight for embroidering. To reduce the tension, press the "-" button.

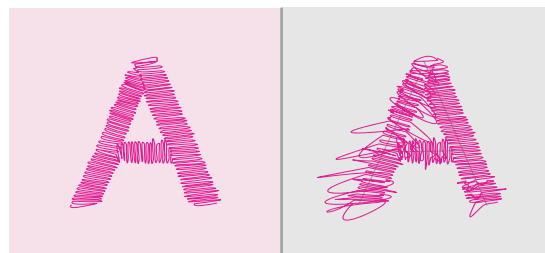

When the upper thread has slack, the thread tension is too loose for embroidering. To increase the tension, press the "+" button.

Note

Please use the same fabric of the project and do a sewing test in advance.

Step 6. Back to sewing mode

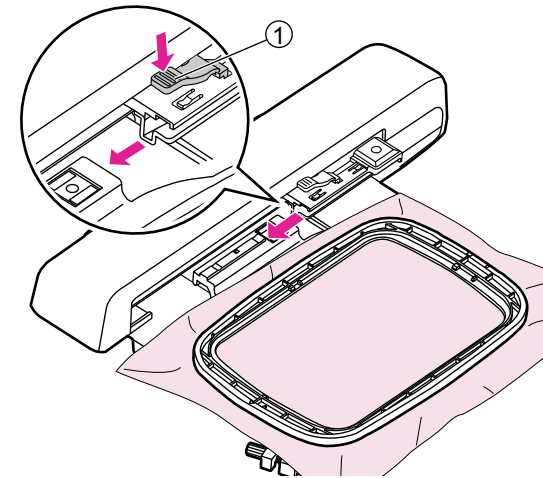

❖ Remove embroidery hoop

Raise the presser foot and confirm the needle is at the highest position. And then press the hoop-securing lever to pull the embroidery hoop backward to remove the embroidery hoop.

- ① Hoop-securing lever

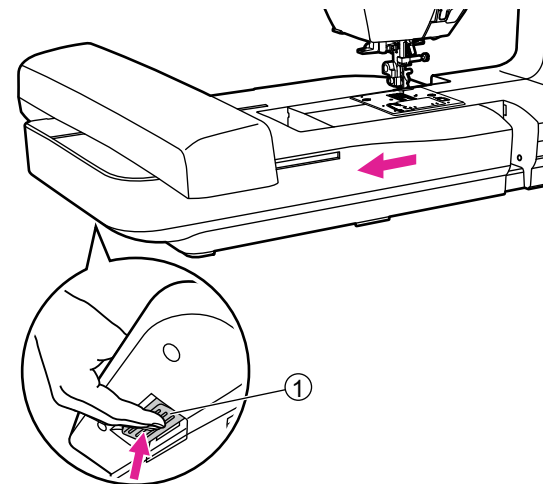

❖ Remove embroidery unit

Hold the embroidery unit and press the release button, then slide the embroidery unit to the left to move out it.

- ① Release button

Note

Please firstly remove the embroidery hoop before removing the embroidery unit.

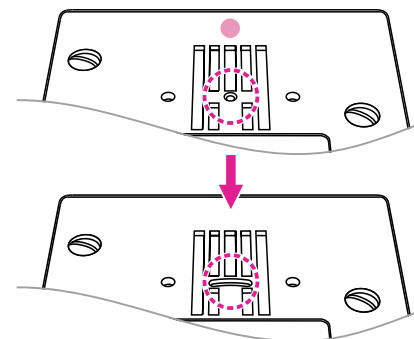

Replacing the straight stitch plate to normal needle plate.

Replacing the needle and presser foot.

Maintenance and Trouble shooting

Maintenance

⚠ Attention

Disconnect the power cord from the wall socket before carrying out any maintenance, otherwise injury or electrical shock may result.

❖ Clean the machine surface

If the surface of the sewing machine is dirty, lightly soak a cloth in mild detergent, squeeze it out firmly and then wipe the surface. After cleaning it once in this way, wipe the surface again with a dry cloth.

Do not use any organic solvents or detergents

❖ Clean the hook

If lint and bits of thread accumulate in the hook, this will interfere with the smooth operation of the machine. Check regularly and clean the stitching mechanism when necessary.

Remove the needle, presser foot and presser foot holder.

Remove the bobbin cover and bobbin.

Remove the screws on the needle plate then remove the needle plate.

- ① Bobbin cover
- ② Screws
- ③ Needle plate

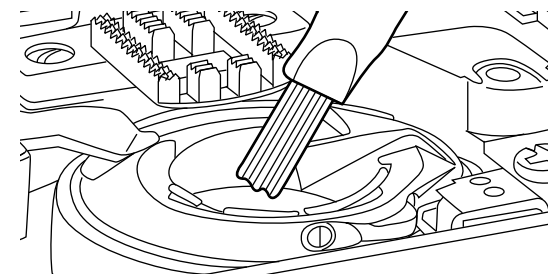
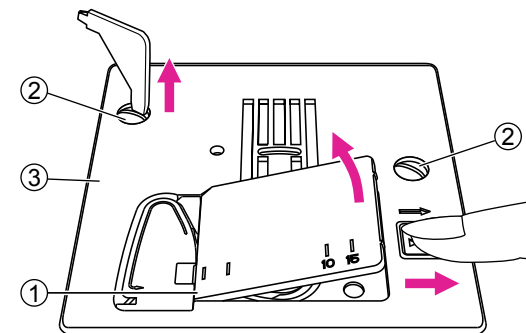

Clean the feed dogs and bobbin case with a brush. And also use a soft and dry cloth to clean them.

Warning Function



❖ Warning beeping sound

- Operate correctly: 1 beep.
- Operate incorrectly: 3-short beeps.
- When the sewing machine is in trouble and can't sew: 1-long beeps.

It means that the thread may be twisted or jammed and the hand wheel axle can't move. Please look through the "Trouble shooting guide" to find the solution. After the problem has been solved, the machine will be able to sew.

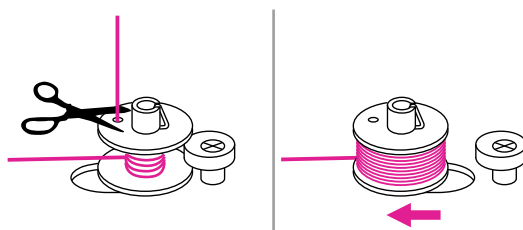

Return bobbin winder spindle to left

When the bobbin thread is full or machine stop, if the bobbin winder spindle is still in the right position, you will hear 3-short beeps by pressing any button until you push the spindle to the left.

Return the bobbin winder spindle to the left.

Note

If the problem is still not solved, please contact your local dealer.

⚠ Attention

During sewing, if the thread has been jammed inside the hook and needle movement stops. If you continue to sew, the machine will stop automatically due to safety. If machine stops, please turn off the machine firstly then turn on again.



❖ Instruction message display

The sewing machine is in trouble

The animation message means that the thread is twisted or jammed and the hand wheel axle cannot move. Please look through the "Trouble shooting guide" to find the solution. When the problem is solved the machine will continue sewing.

Trouble shooting guide

Before calling for service, check below trouble shooting guides in advance, if problem still exist, please contact nearest dealer or local service center.

| Problem | Cause | Correction | Reference |
|----------------------|---|---|-----------|
| Upper thread breaks | 1. The machine is not threaded correctly. | 1. Rethread the upper thread. | 13-15 |
| | 2. The thread tension is too tight. | 2. Reduce the thread tension (to lower number). | 22 |
| | 3. The thread is too thick for the needle. | 3. Select a larger needle size. | 18 |
| | 4. The needle is not inserted correctly. | 4. Remove and reinsert the needle (flat side towards the back). | 17 |
| | 5. The thread is wound around the spool holder pin. | 5. Remove the reel and wind up the thread onto the reel. | 13 |
| | 6. The needle is damaged. | 6. Insert a new needle. | 17 |
| Bobbin thread breaks | 1. The bobbin case is not inserted correctly. | 1. Remove and reinsert the bobbin case and pull on the thread. | 12 |
| | 2. The bobbin case is threaded wrong. | 2. Check both bobbin and bobbin case if on the correct position. | 12 |
| Skipped stitches | 1. The needle is not inserted correctly. | 1. Remove and reinsert the needle (flat side towards the back). | 17 |
| | 2. The needle is damaged. | 2. Insert a new needle. | 17 |
| | 3. The wrong size needle has been used. | 3. Choose a needle to suit the thread. | 18 |
| | 4. The presser foot is not attached correctly. | 4. Check and attach it correctly. | 19 |
| | 5. The machine is not threaded correctly. | 5. Rethread the upper thread. | 13-15 |
| Needle breaks | 1. The needle is damaged. | 1. Insert a new needle. | 17 |
| | 2. The needle is not correctly inserted. | 2. Insert the needle correctly (flat side towards the back). | 17 |
| | 3. Wrong needle size for the fabric. | 3. Choose a needle to suit the thread and fabric. | 18 |
| | 4. The wrong presser foot is attached. | 4. Select the correct presser foot. | - |
| | 5. The needle clamp screw is loose. | 5. Use the screwdriver to tighten the screw. | 17 |
| | 6. The presser foot is not appropriate for the type of stitch that you sew. | 6. Attach appropriate presser foot for the type of stitch that you sew. | - |
| | 7. The upper thread tension too tight. | 7. Loosen the upper thread tension. | 22 |

| Problem | Cause | Correction | Reference |
|------------------------------|---|--|-----------|
| Loose stitches | 1. The machine is not correctly threaded. | 1. Check the threading and rethread. | 13-15 |
| | 2. The bobbin case is not threaded correctly. | 2. Thread the bobbin case as illustrated. | 10-12 |
| | 3. Needle/fabric/thread combination is wrong. | 3. The needle size must suit the fabric and thread. | 18 |
| | 4. The thread tension is wrong. | 4. Correct the thread tension. | 22 |
| Seam gather or pucker | 1. The needle is too thick for the fabric. | 1. Select a correct needle size. | 18 |
| | 2. The stitch length is wrong. | 2. Adjust the stitch length. | 28 |
| | 3. The thread tension is too tight. | 3. Loosen the thread tension. | 22 |
| Seam puckering | 1. The needle thread tension is too tight. | 1. Loosen the thread tension. | 22 |
| | 2. The needle thread is not threaded correctly. | 2. Rethread the machine. | 13-15 |
| | 3. The needle is too heavy for the fabric being sewn. | 3. Choose a needle to suit the thread and fabric. | 18 |
| | 4. The stitch length is too long for the fabric. | 4. Adjust the stitch length shorter. | 28 |
| | 5. Sewing on thin fabric. | 5. Sew with a stabilizer material under the fabric. | 39 |
| Patterns are distorted | 1. The presser foot is not suited for the pattern. | 1. Select the correct foot. | - |
| | 2. The needle thread tension is too tight. | 2. Loosen the thread tension. | 22 |
| Thread has jammed | 1. Thread is caught in the hook. | Remove the upper thread and bobbin case, turn the handwheel backwards and forwards and remove the thread remnants. | 89 |
| | 2. The feed dogs are packed with lint. | | |
| The machine is noisy | 1. Fluff or oil have collected on the hook or needle bar. | 1. Clean the hook and feed dog. | 89 |
| | 2. The needle is damaged. | 2. Insert a new needle. | 17 |
| | 3. Thread is caught in the hook. | Remove the upper thread and bobbin case, turn the handwheel backwards and forwards and remove the thread remnants. | 89 |
| | 4. The feed dogs are packed with lint. | | |
| Uneven stitches, uneven feed | 1. Poor quality thread. | 1. Select a better quality thread. | 18 |
| | 2. The bobbin case is threaded uncorrect. | 2. Remove the bobbin case and the thread and reinsert them correctly. | 10-12 |
| | 3. Fabric has been pulled on. | 3. Do not pull on the fabric while sewing, let it be taken up by the machine. | - |

| Problem | Cause | Correction | Reference |
|------------------------------------|---|--|-----------|
| The sewing machine doesn't operate | 1. The machine is not turned on. | 1. Turn on the machine. | 3 |
| | 2. The presser foot lifter is raised. | 2. Lower the presser foot lifter. | 9 |
| | 3. The machine is not plugged in. | 3. Connect the power cord to the electric outlet. | 3 |
| Embroidery unit does not move | 1. The embroidery unit is not set up correctly. | 1. Reset the embroidery unit up correctly. | 77 |
| Embroidery is not neatly completed | 1. The thread is tangled and the bobbin case, etc., is plugged up. | 1. Remove the tangled thread. When the bobbin case is plugged up, clean the race. | 89 |
| | 2. The thread tension is incorrect. | 2. Adjust the tension of the upper thread. | 86 |
| | 3. The fabric is not fully stretched on the embroidery hoop. The fabric is loose. | 3. Stretch the fabric properly on the embroidery hoop. | 72 |
| | 4. No stabilizer material is attached. | 4. Always use stabilizer material for embroidery with stretch fabrics, thin fabrics, fabrics with a loose weave and fabrics where stitches easily contract. | 70-71 |
| | 5. Objects are placed near the carriage or embroidery hoop. | 5. If the embroidery unit carriage or embroidery hoop bumps into objects, the pattern will be misaligned. Do not place objects within the range of embroidery hoop motion. | - |
| | 6. Material coming out of the embroidery hoop is causing problems. | 6. Stretch the fabric on the hoop once again so that the material coming out of the embroidery hoop does not cause problems, rotate the pattern and embroider. | - |
| | 7. Embroider with a heavy fabric or the fabric material is hanging on the table. | 7. During embroidery, if the fabric is hanging on the table will affect the embroidery unit movement, please hold the fabric gently in this case. | - |
| | 8. The fabric is catching. It is pinched. | 8. Stop the sewing machine and set the fabric up correctly. | - |
| | 9. The embroidery carriage was moved while the embroidery hoop was being removed or attached during embroidery. | 9. If the embroidery carriage is moved during the process, the pattern may be misaligned. Be careful when removing or attaching the embroidery hoop. | - |

| Problem | Cause | Correction | Reference |
|--|--|--|-----------|
| Embroidery machine connection issue | 1. When starting the machine in router mode, the machine screen displays "E5" from "AP". | 1. The connection failed because the router might not be in operation or the password is not correct. A.If it was the first time for setting, please check if the password is correct. B.If the router mode had already been set up successfully, please check if the router works normally and is well connected. | 79 |
| | 2. No WiFi base station and signal in the current environment. | 2. Please use the default point-to-point mode for connection. It allows a direct connection to the machine without via a WiFi router. | 81 |
| | 3. When the machine power is turned on, the screen displays "SP" but no connection action was performed. | 3. Bobbin winder spindle is on the right for bobbin winding. Push the spindle to the left for sewing. | 11 |
| | 4. When the machine screen displays "E1". | 4. Presser foot lifter is not raised or should be lowered. | 5 |
| | 5. When the machine screen displays "E2" | 5. Embroidery hoop is not installed or should be removed. | 5 |
| | 6. When the machine screen displays "E3" | 6. Please replace the straight stitch plate. | 5 |
| | 7. Connection is unstable and it disconnects all the time. | 7. Please place the machine and handheld device near the WiFi station as close as possible. Interference will be impacted easily if there are several wireless signals in the environment; it suggest to change to point-to-point mode connection. | 81 |
| The embroidery result is not good enough | 1. The thread tension is not right. | 1. Adjust to proper thread tension setting. | 86 |
| | 2. Poor quality thread. | 2. Select a better quality thread and attach spool net to thread. | 9 |
| | 3. The thread tends to break and out the thread spool easily while using particular thread type. | 3. Attach spool net on the thread. | 9 |
| | 4. The wrong size needle has been used. | 4. Choose a proper needle according to the fabric. | 18 |
| | 5. No enough support due to lack of stabilizer. | 5. Use a proper stabilizer according to fabric type. | 66 |

| Problem | Cause | Correction | Reference |
|--|---|---|-----------|
| The embroidery result is not good while sewing thin fabric | 1. The thread tension is not right. | 1. Set a smaller thread tension. | 86 |
| | 2. Poor quality thread. | 2. Select a better quality thread. | - |
| | 3. The wrong size needle has been used. | 3. Choose a needle size between 9-11 by your fabric type. | 18 |
| | 4. No enough support due to lack of stabilizer. | 4. Use a proper stabilizer according to fabric type. | 66 |
| Poor quality for cotton batting | 1. The thread tension is wrong. | 1. Adjust to proper tension setting. (number between 3-5) | 22 |
| | 2. The stitch length is wrong. | 2. Adjust to proper stitch length. (number between 3.0-4.0) | 28 |

Embroidery pattern chart

Floral & Plant

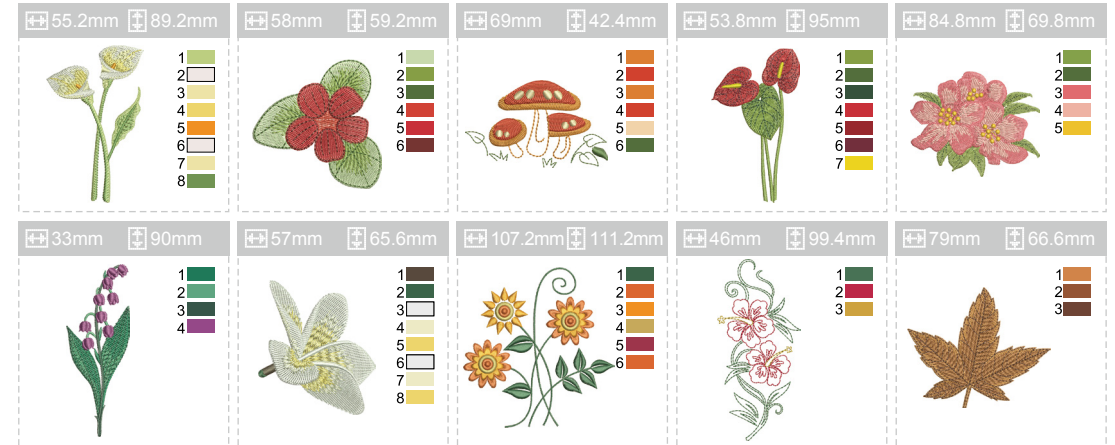

Animal



Frame

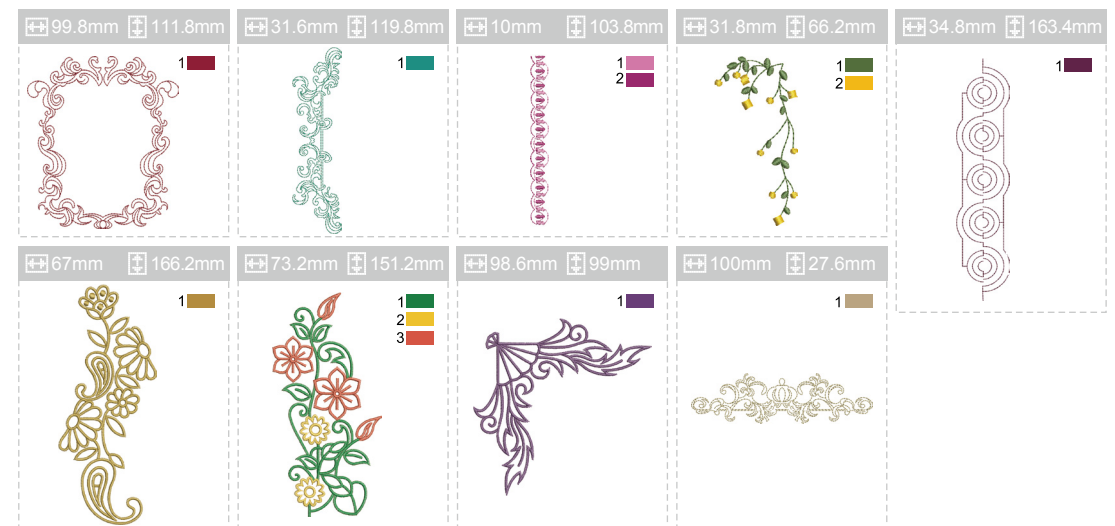

Embroidery pattern chart

■ Totem



■ Sport

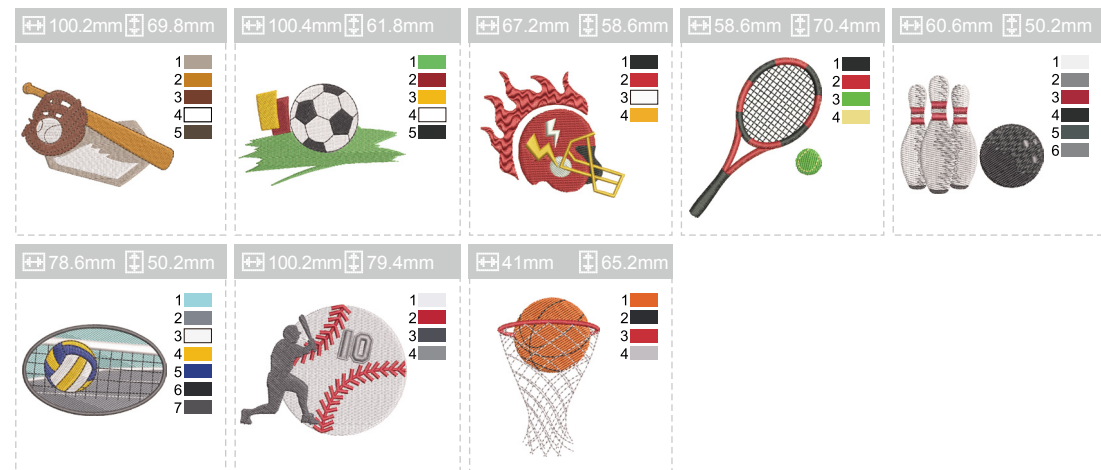

■ Christmas

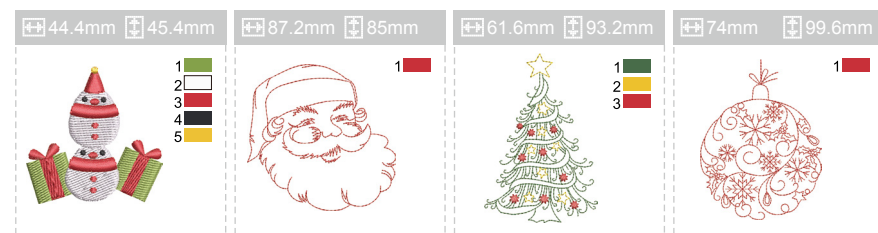

■ Halloween

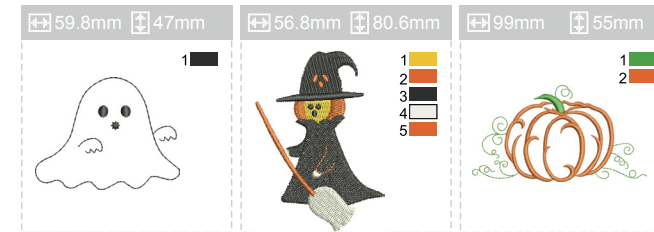

■ Houseware

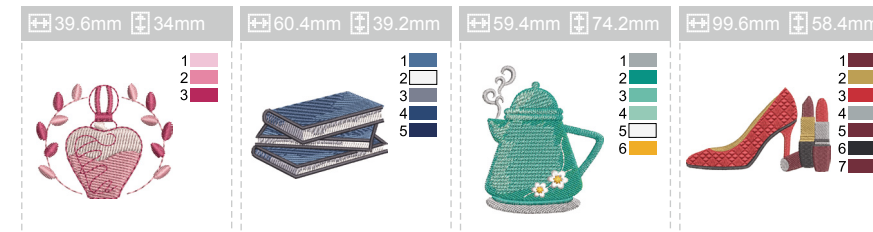

■ Scenery

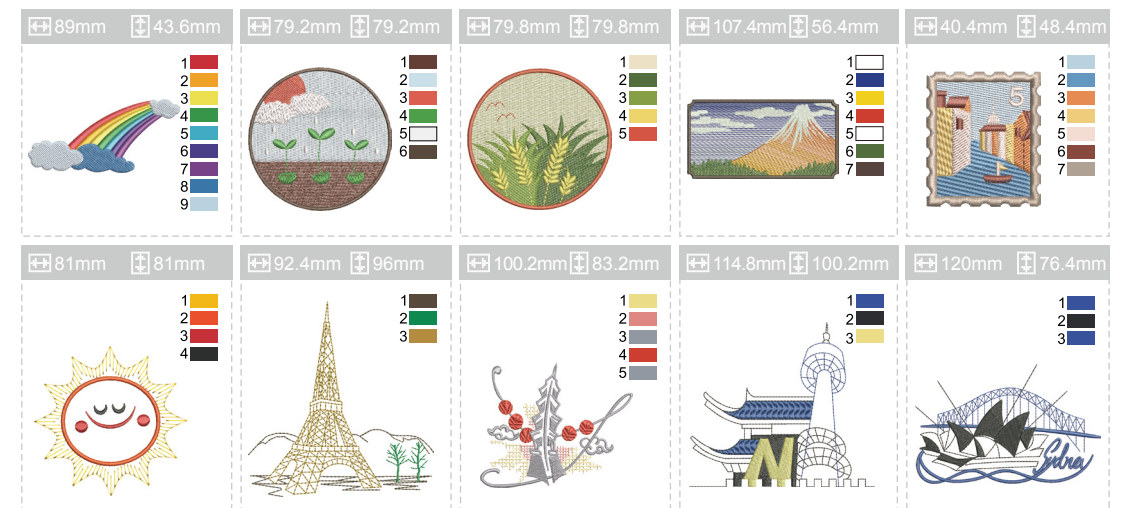

VERITAS®

 www.veritas-sewing.com

 www.facebook.com/veritassewing



MyPatterns



GET IT ON
Google Play



Download on the
App Store